



MP80 FG

Micro Pitch Modular Belt Series

- **Bakery Applications**

Row Dough Handling, Divider, Proofer Lines, Laminating Lines

- **Meat Applications**

Transfer - Crossover Conveyance and Metal Detectors

- **Seafood Applications**

Grading Lines and Weighing Lines

- **Fruits and Vegetables Applications**

Control and Sorting Tables

- **Snack Food Applications**

Cooling Lines

- **Beverage Applications**

Box Transfer

MP80 FG

Pitch:	8 mm / 0.315 inch
Belt Surface:	Open, Smooth Surface
Minimum Width:	101,6 mm / 4 inch
Open Area (%):	34%. (Biggest opening)
Flight:	No
Sidewall:	No
Rod:	Ø3 mm / 0.118 inch
Approved:	FDA and EU
Curve:	No
Color:	Additional colors av:
Cleanability:	Good
Belt Thickness:	6 mm / 0.236 inch
Min. Nosebar Diameter:	6 mm / 0.236 inch

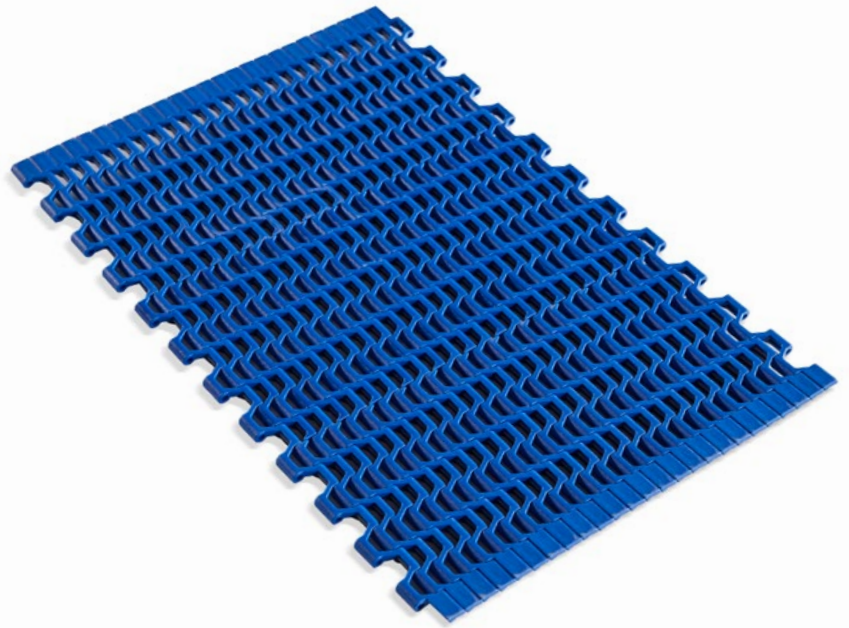

Product Features and Functional Benefits

- Micro pitch series with small transfer gaps for tight transfer.
- Designed to run over nosebars/knife edges or rollers with a radius down to 3mm (**0.12 inch**) allowing, precise transfer of even the smallest products.
- Versatile for conveying, drying and cooling applications.
- Optimal design of sprocket teeth, and belt underside provides superior sprocket engagement, safe belt tracking and favorable cleanability.
- Headless pin making it very easy to install and remove the belt for maintenance.

Available Moulded Module Sizes

- 203,2 mm / **8 inch** module
- 101,6 mm / **4 inch** module

MP80 FG / Technical Information

BELT / PIN MATERIAL	BELT STRENGTH				TEMPERATURE		BELT WEIGHT Kg/m ² / lb/ft ²
	Straight		Curve		°C / °F (min.)	°C / °F (max.)	
	N/m	lb/ft	N/m	lb/ft			
Acetal / Acetal	2650	181	-	-	-43 / -45.4	+110 / +230	4,4 / 0.90

- Belt strength and temperature values are maximum on the table.

MP80 FG / Standard Belt Widths

BELT SERIES	WIDTH (W)				Belt With Tolerance (max.)
	PP-PE		POM		
	mm	inch	mm	inch	
MP80 FG	-	-	101,6	4.0	± 1 mm
MP80 FG	-	-	203,2	8.0	± 1 mm
MP80 FG	-	-	304,8	12.0	± 1 mm
MP80 FG	-	-	406,4	16.0	± 1 mm
MP80 FG	-	-	508,0	20.0	± 2 mm
MP80 FG	-	-	609,6	24.0	± 2 mm
MP80 FG	-	-	711,2	28.0	± 2 mm
MP80 FG	-	-	812,8	32.0	± 2 mm
MP80 FG	-	-	914,4	36.0	± 2 mm

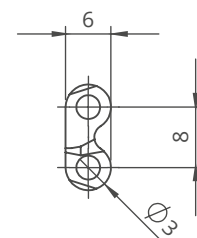
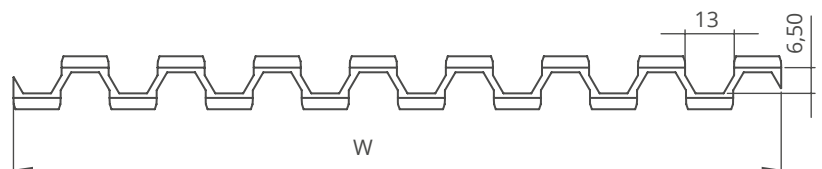

- Standard belt increments 101,6 mm.
 - Non-standard belt increments 25,4 mm.
- Please contact with customer service for precise belt measurements.



MP80 (Micro Pitch Series)

Technical Specifications

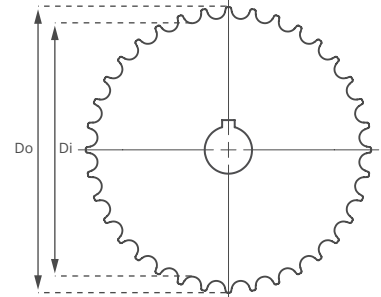
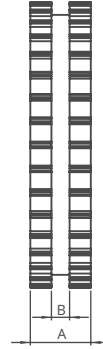
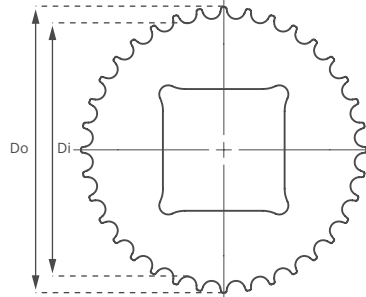
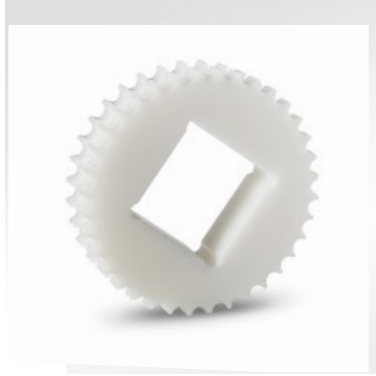

MP80 Micro Pitch Series / Machined Sprockets Dimensions

NO.TEETH	Di mm/inch	Do mm/inch	B mm/inch	A mm/inch	Square Bore (Q) mm/inch	Round Bore (R) mm/inch	PRODUCT CODE	
							Square Type (Q)	Round Type (R)
Z18	40,9 / 1.61	48,0 / 1.89	6 / 0.23	20 / 0.78	20 / 0.78	25 / 1	MP80SQZ18	MP80SRZ18
Z24	56,4 / 2.22	63,7 / 2.51	6 / 0.23	20 / 0.78	25 / 1	25-30 / 1-1.25	MP80SQZ24	MP80SRZ24
Z36	87,5 / 3.44	94,9 / 3.74	6 / 0.23	20 / 0.78	40 / 1.57	25-30 / 1-1.25	MP80SQZ36	MP80SRZ36

*All required sprockets produced by CNC.

*Other sprockets and hub sizes are manufactured up to request.

*POM (Acetal) and PA (Polyamide) sprockets raw material is available on request.

***Machined Split Sprockets are available for each size.**



Precise transfer even the smallest products!

Micropitch belt series are suitable to run 6 mm nosebar roller.



MP80 Series *Engineering Information*

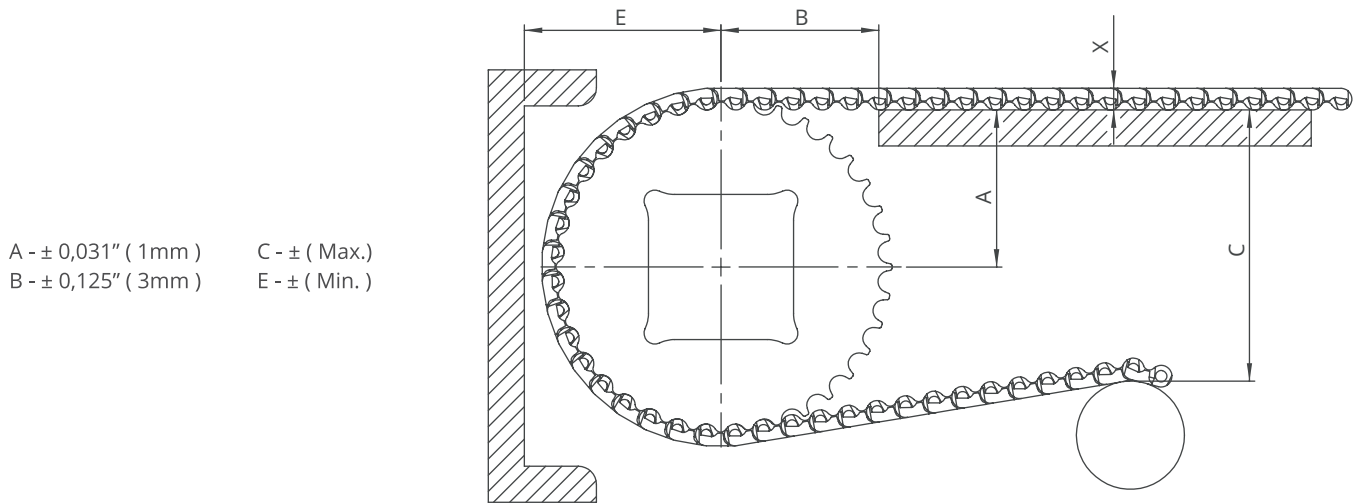

A - ± 0,031" (1mm) C - ± (Max.)
 B - ± 0,125" (3mm) E - ± (Min.)

MP80 Series / Conveyor Frame Dimensions

Sprockets Description		A		B		C		E		X		
Pitch Diameter		Range (Bottom to Top)		Inch	mm	Inch	mm	Inch	mm	Inch	mm	
Inch	mm	Inch	mm									
MP80 C, MP80 FG, MP80 NP, MP80 NS												
1.85	47,0	18	0.81	20,5	1.18	30,0	1.12	28,5	1.24	31,5	0.24	6,0
1.95	49,5	24	1.11	28,3	1.38	35,0	1.73	44,0	1.55	39,3	0.24	6,0
3.68	93,5	36	1.72	43,8	1.77	45,0	2.95	75,0	2.16	54,8	0.24	6,0

MP80 Series / Slider Support System For Straight Running Belts

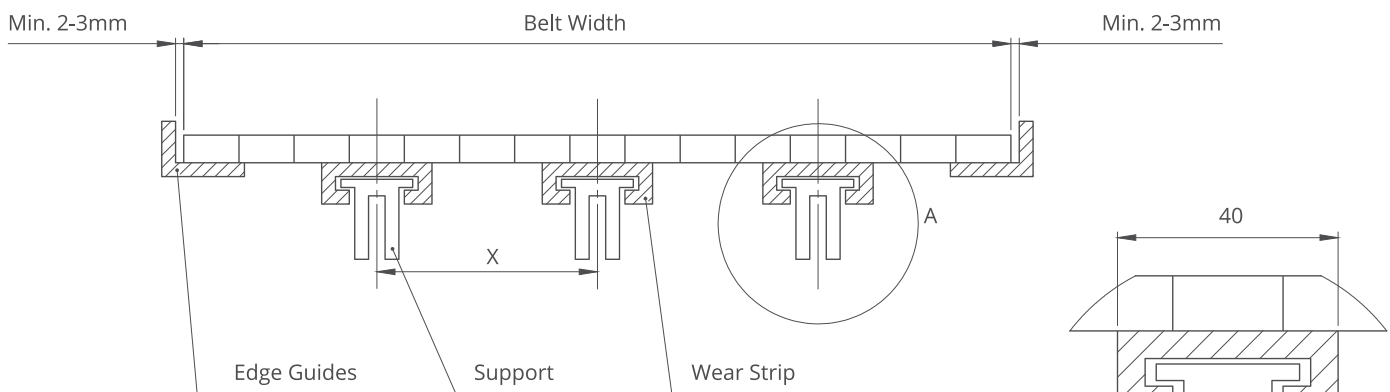

Note: The max. distances between the wear strips have to be (X) ;

125 mm for 2" belts
 80 mm for 1" / 0.5" belts

Detail A
 Scale 1:1

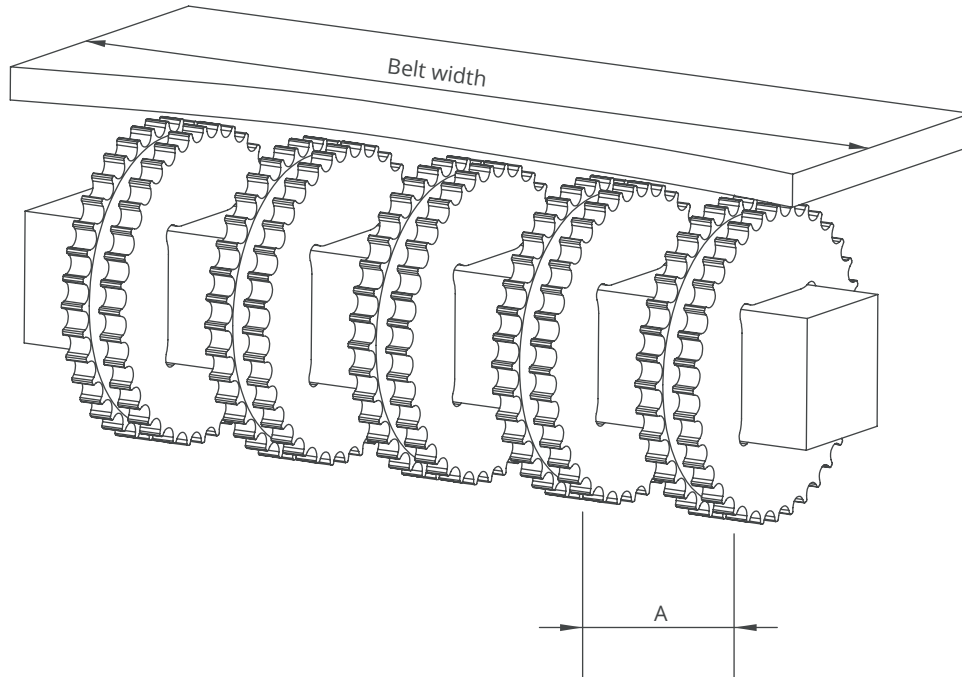

MP80 Series / Sprockets Arrangement

Standard Belt Width		Number of sprockets per shaft		A (mm/inch)	
mm	inch	Drive Shaft	Return Shaft	Min.	Max.
101,6	4.0	2	2	50/2	100/4
203,2	8.0	3	2	50/2	100/4
304,8	12.0	4	3	50/2	100/4
406,4	16.0	5	3	50/2	100/4
508,0	20.0	6	4	50/2	100/4
609,6	24.0	7	5	50/2	100/4
711,2	28.0	8	6	50/2	100/4
812,8	32.0	9	7	50/2	100/4
914,4	36.0	10	8	50/2	100/4
1016,0	40.0	11	9	50/2	100/4
1117,6	44.0	12	9	50/2	100/4
1219,2	48.0	13	10	50/2	100/4
1320,8	52.0	14	11	50/2	100/4
1422,4	56.0	14	11	50/2	100/4
1524,0	60.0	15	12	50/2	100/4
1625,6	64.0	16	12	50/2	100/4