



EC508 C

Modular Belt Series

• Meat Applications

*Slaughtering - Evisceration, Cutting Lines, Debonning Lines,
Bone Takeaway, Dressing Lines, Trim Lines*

• Poultry Applications

*Live Birds, Slaughtering - Evisceration, Skinning, Cut - Up,
Chiller Discharge, Bird Accumulation, Freezing Lines, Elevator*

• Sea Food Applications

Trim Lines, Control Tables, Glazing, Elevator

• Bakery Applications

Row Dough Handling, Laminating Lines

• Snack Food Applications

Potato Processing

• Fruits and Vegetables Applications

Bulk Feeding, Elevator, Control Sorting Table, Filling

• Automotive Applications

Chair Lift - Feeder

• Packaging Applications

Bluk Inclines, Box Transport Horizontal



MODUTECH

EC508 C

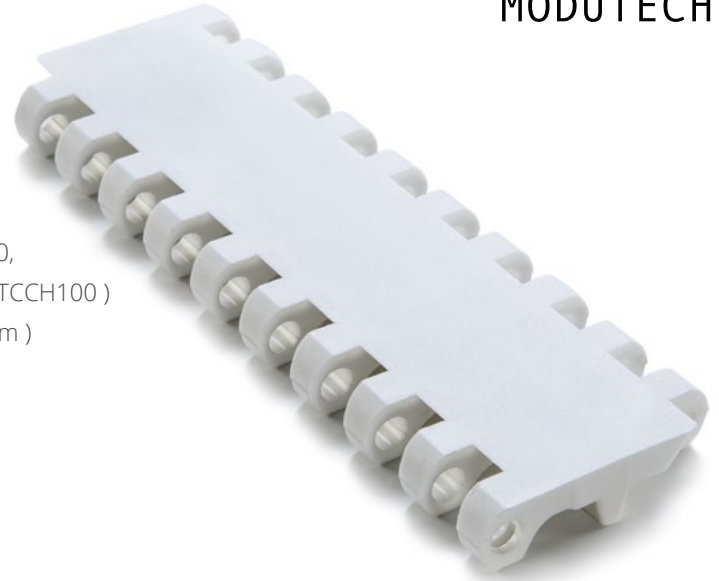

Pitch:	50,8 mm / 2 inch
Belt Surface:	Close, Smooth Surface
Minimum Width:	100 mm / 3.94 inch
Open Area (%):	0%
Flight:	Yes (T25, T50, T75, T100, T150, TNC50, TNC100, TC75, TC100, TC150, TCC75, TCC100, TCC150, TCCH100)
Sidewall:	Yes (h=25 mm, h=50 mm, h=75 mm, h=100 mm)
Rod:	Ø7 mm / 0.276 inch - Self Lock
Approved:	FDA and EU
Curve:	No
Color:	Additional colors available
Cleanability:	Excellent
Belt Thickness:	16 mm / 0.630 inch

Product Features and Functional Benefits

- Easy to clean reduces downtime for cleaning time 70%.
- Close transfer applications.
- Reduces bacteria growth.
- Unique sprocket engagement - higher product load and longer conveyors.
- Strong and thick product supports allow more load without breaking.
- Impact resistance to withstand heavy objects falling into the belt.

Available Moulded Module Sizes

- 200 mm / **7.87 inch** module
- 100 mm / **3.94 inch** module
- 60 mm / **2.36 inch** module
- 40 mm / **1.57 inch** module

EC508 C / Technical Information

BELT MATERIAL	BELT STRENGTH				TEMPERATURE		BELT WEIGHT
	Straight		Curve		°C / °F (min.)	°C / °F (max.)	
	N/m	lb/ft	N/m	lb/ft			Kg/m ² / lb/ft ²
Polypropylene	19800	1356	-	-	+5 / +41	+90 / +194	9,0 / 1.85
Polyethylene	11000	753	-	-	-73 / -99.4	+66 / +150.8	9,4 / 1.93
Acetal	33000	2260	-	-	-43 / -45.4	+110 / +230	13,5 / 2.77

- Belt strength and temperature values are maximum on the table.

EC508 C / Standard Belt Widths

BELT SERIES	WIDTH (W)				Belt With Tolerance (max.)
	PP-PE		POM		
	mm	inch	mm	inch	
EC 508 C	200,0	7.87	200,0	7.87	± 1 mm
EC 508 C	300,0	11.81	300,0	11.81	± 2 mm
EC 508 C	400,0	15.75	400,0	15.75	± 2 mm
EC 508 C	500,0	19.69	500,0	19.69	± 2 mm
EC 508 C	600,0	23.62	600,0	23.62	± 3 mm
EC 508 C	700,0	27.56	700,0	27.56	± 3 mm
EC 508 C	800,0	31.50	800,0	31.50	± 3 mm
EC 508 C	900,0	35.43	900,0	35.43	± 4 mm
EC 508 C	1000,0	39.37	1000,0	39.37	± 4 mm
EC 508 C	1100,0	43.31	1100,0	43.31	± 4 mm
EC 508 C	1200,0	47.24	1200,0	47.24	± 4 mm
EC 508 C	1300,0	51.18	1300,0	51.18	± 5 mm
EC 508 C	1400,0	55.11	1400,0	55.11	± 5 mm
EC 508 C	1500,0	59.06	1500,0	59.06	± 5 mm

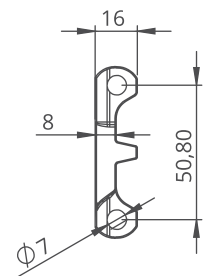
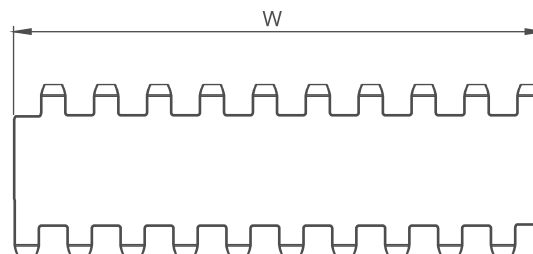

- Standard belt increments 100 mm.
- Non-standard belt increments 20 mm.
- Please contact with customer service for precise belt measurements.

EC508 Series Sprockets and Technical Specifications

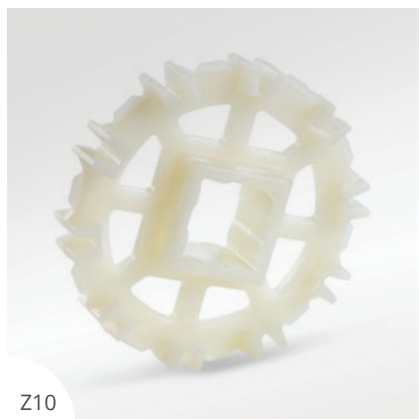

Z10



Z10



Z12

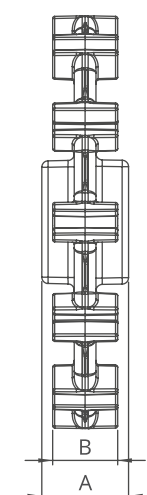
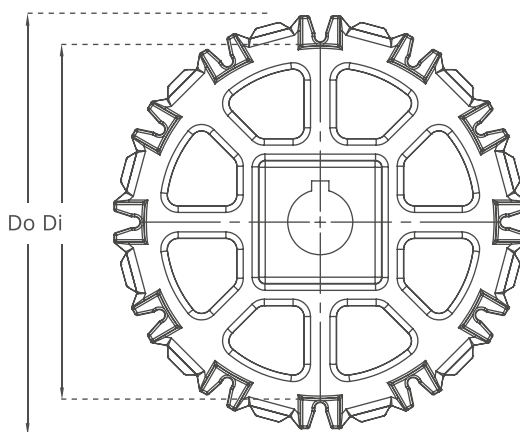
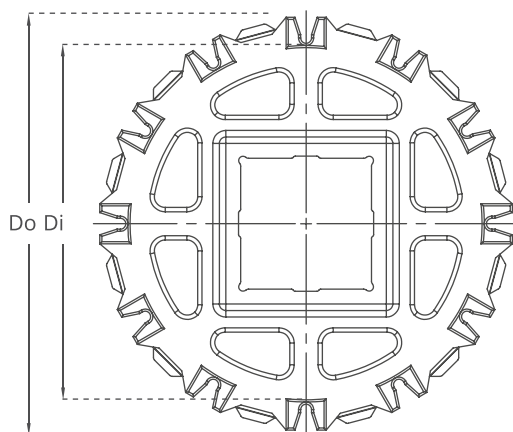

EC508 Series / Standard Sprockets Dimensions

NO. TEETH	Di mm/inch	Do mm/inch	B mm/inch	A mm/inch	Square Bore(Q) mm/inch	Round Bore(R) mm/inch	PRODUCT CODE	
							Square Type (Q)	Round Type (R)
Z6	73,0 / 2.87	90,0 / 3.54	30 / 1.18	40 / 1.57	40 / 1.5	25-30 / 1-1.25	EC508SQZ6*PA	EC508SRZ6*PA
Z8	107,5 / 4.23	124,5 / 4.90	30 / 1.18	40 / 1.57	40 / 1.5	25-30 / 1-1.25	EC508SQZ8*PA	EC508SRZ8*PA
Z10	141,5 / 5.57	158,0 / 6.22	30 / 1.18	40 / 1.57	40-60 / 1.5-2.5	25-30 / 1-1.25	EC508SQZ10*PA	EC508SRZ10*PA
Z12	175,2 / 6.90	191,2 / 7.53	30 / 1.18	40 / 1.57	40-60 / 1.5-2.5	25-30 / 1-1.25	EC508SQZ12*PA	EC508SRZ12*PA

*Other sprockets and hub sizes are manufactured up to request.

*POM (Acetal) and PP (Polypropylene) sprockets raw material is available on request.

***Machined Split Sprockets are available for each size.**



Clamp



Machined Split Sprocket

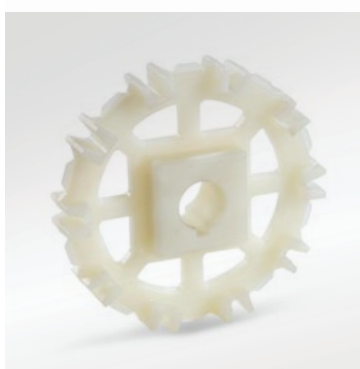

Moulded Sprocket

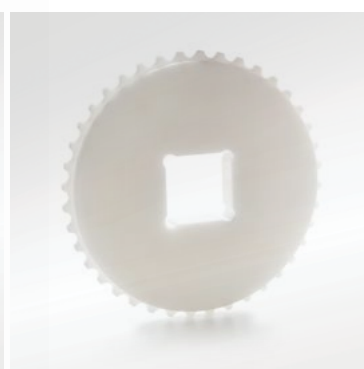

Machined Sprocket



MODUTECH

EC508 Series Accessories and Technical Specifications

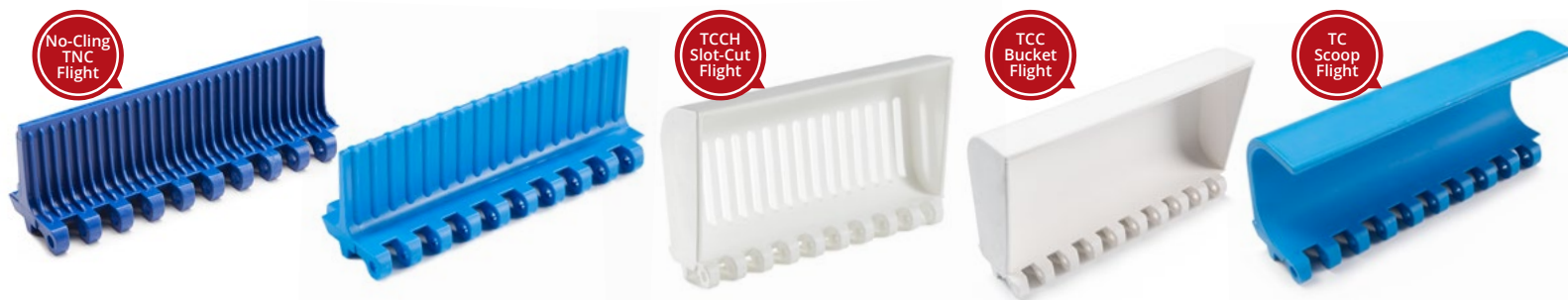

EC508 Series / Flight & Sidewall Dimensions

EC508 Series / Flights & Sidewalls				
PRODUCT CODE	Flight Height (mm/ <i>inch</i>)	Flight Width (mm/ <i>inch</i>)	PRODUCT CODE	Sidewall Height (mm/ <i>inch</i>)
EC508T25	25 / 1	200 / 7.87	EC508SW25	25 / 1
EC508T50	50 / 2	200 / 7.87	EC508SW50	50 / 2
EC508T75	75 / 3	200 / 7.87	EC508SW75	75 / 3
EC508T100	100 / 4	200 / 7.87	EC508SW100	100 / 4
EC508T150	150 / 6	200 / 7.87	-	-
EC508TC75	75 / 3	200 / 7.87	-	-
EC508TC100	100 / 4	200 / 7.87	-	-
EC508TC150	150 / 6	200 / 7.87	-	-
EC508TCC75	75 / 3	200 / 7.87	-	-
EC508TCC100	100 / 4	200 / 7.87	-	-
EC508TCC150	150 / 6	200 / 7.87	-	-
EC508TNC100	100 / 4	200 / 7.87	-	-
EC508TCH100	100 / 4	200 / 7.87	-	-
EC508TCCH100	100 / 4	200 / 7.87	-	-

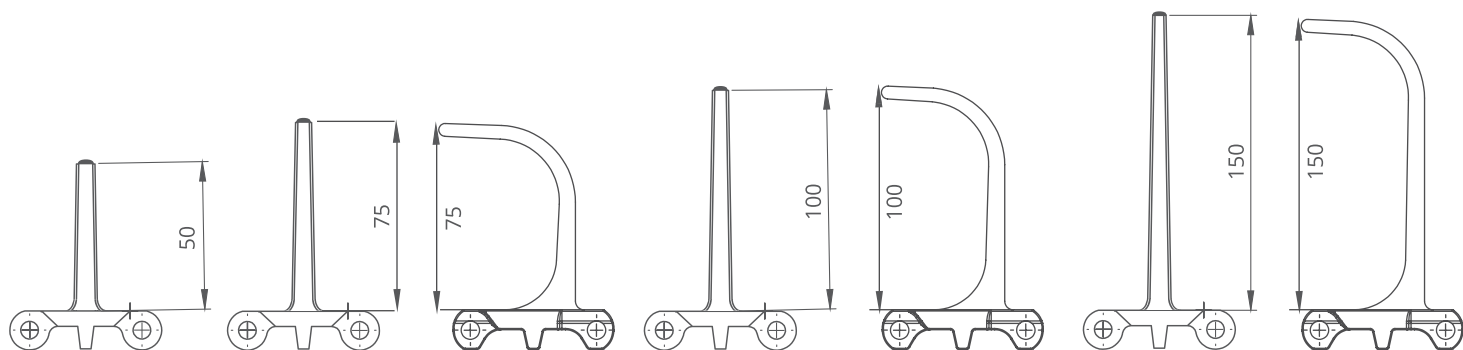

* Additional flight dimensions are available up to 150 mm.

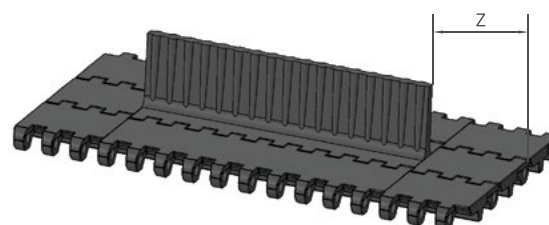
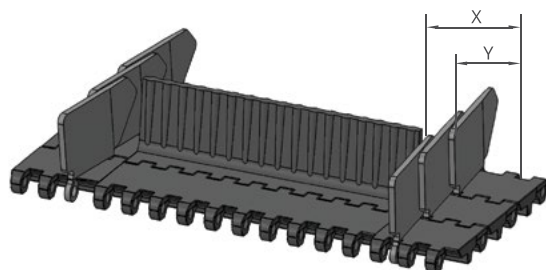

EC508 Series / Sidewall Technical Specifications

Possible Sidewall and Flight Indents	X		Y	
	mm	<i>inch</i>	mm	<i>inch</i>
Standard, no module cutting	32,0	1.26	20,0	0.79
Module cutting necessary	42,0	1.65	30,0	1.18
Standard, no module cutting	52,0	2.05	40,0	1.57
Module cutting necessary	62,0	2.44	50,0	1.97
Standard, no module cutting	72,0	2.83	60,0	2.36
Module cutting necessary	82,0	3.23	70,0	2.76

EC508 Series / Flight Technical Specifications

Possible Flight Indents for EC508 Series	Z	
	mm	<i>inch</i>
Standard, no module cutting	40,0	1.57
Standard, no module cutting	60,0	2.36
Standard, module cutting	80,0	3.15
Standard, no module cutting	100,0	3.94

*Non-standard flight indent is on request.

Note: Gap between flight and sidewall minimum 2-3 mm

www.modutech.com.tr

EC508 Series *Engineering Information*

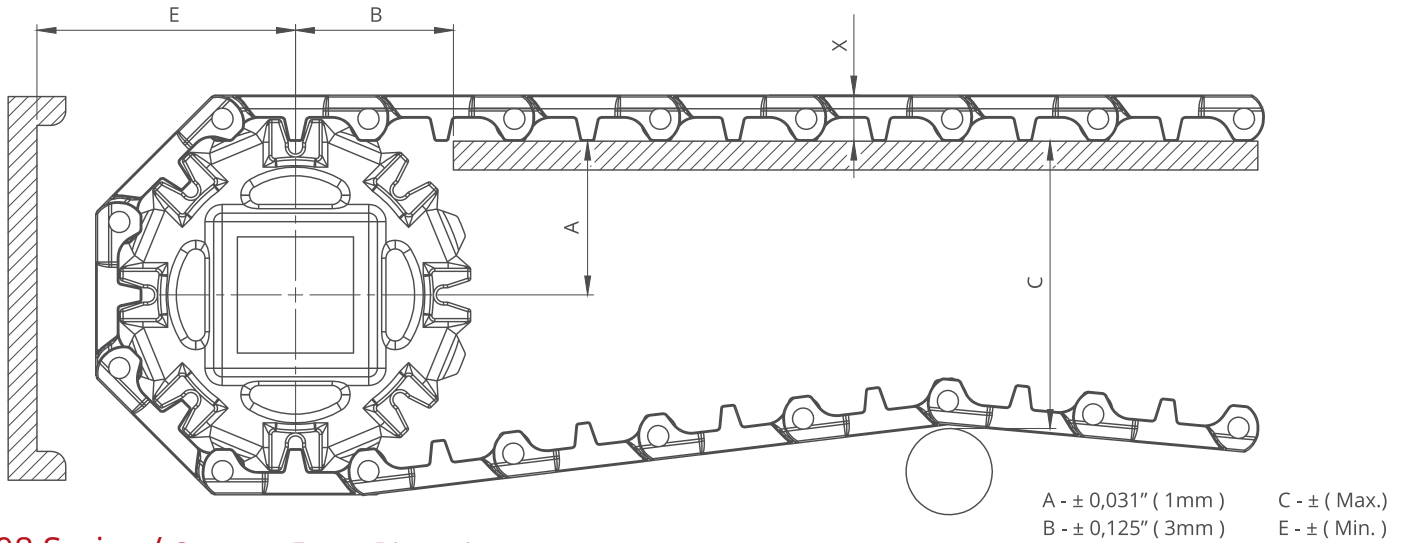

EC508 Series / Conveyor Frame Dimensions

Sprockets Description			A		B		C		E		X	
Pitch Diameter		No.Teeth	Range (Bottom to Top)		inch	mm	inch	mm	inch	mm	inch	mm
inch	mm		inch	mm								
EC508 C, EC508 PR%22, EC508 PR%13, EC508 PR%11, EC508 FG												
3.23	82,0	6	1.70	43,3	1.72	43,8	2.92	74,3	2.73	69,3	0.63	16,0
4.57	116,0	8	2.34	59,4	2.08	52,7	4.23	107,4	3.36	85,4	0.63	16,0
5.91	150,0	10	2.96	75,3	2.38	60,5	5.52	140,3	3.99	101,3	0.63	16,0
7.23	183,6	12	3.65	92,8	2.58	65,5	6.87	174,6	4.68	118,8	0.63	16,0
EC508 DT												
3.23	82,0	6	1.70	43,3	1.72	43,8	2.92	74,3	2.73	69,3	0.67	17,0
4.57	116,0	8	2.34	59,4	2.08	52,7	4.23	107,4	3.36	85,4	0.67	17,0
5.91	150,0	10	2.96	75,3	2.38	60,5	5.52	140,3	3.99	101,3	0.67	17,0
7.23	183,6	12	3.65	92,8	2.58	65,5	6.87	174,6	4.68	118,8	0.67	17,0
EC508 NT, EC508 FG-NT												
3.23	82,0	6	1.70	43,3	1.72	43,8	2.83	71,8	2.83	71,8	0.73	18,5
4.57	116,0	8	2.34	59,4	2.08	52,7	4.13	104,9	3.46	87,9	0.73	18,5
5.91	150,0	10	2.96	75,3	2.38	60,5	5.43	137,8	4.09	103,8	0.73	18,5
7.23	183,6	12	3.65	92,8	2.58	65,5	6.78	172,1	4.78	121,3	0.73	18,5

EC508 Series / Slider Support System For Straight Running Belts

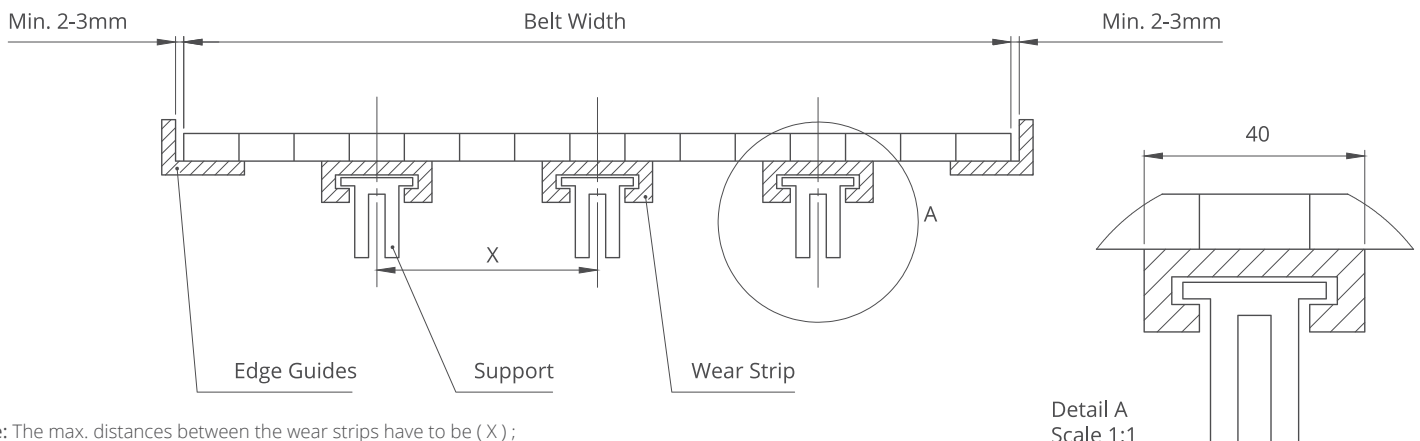

Note: The max. distances between the wear strips have to be (X) ;
 125 mm for 2" belts. 80 mm for 1" / 0.5" belts.

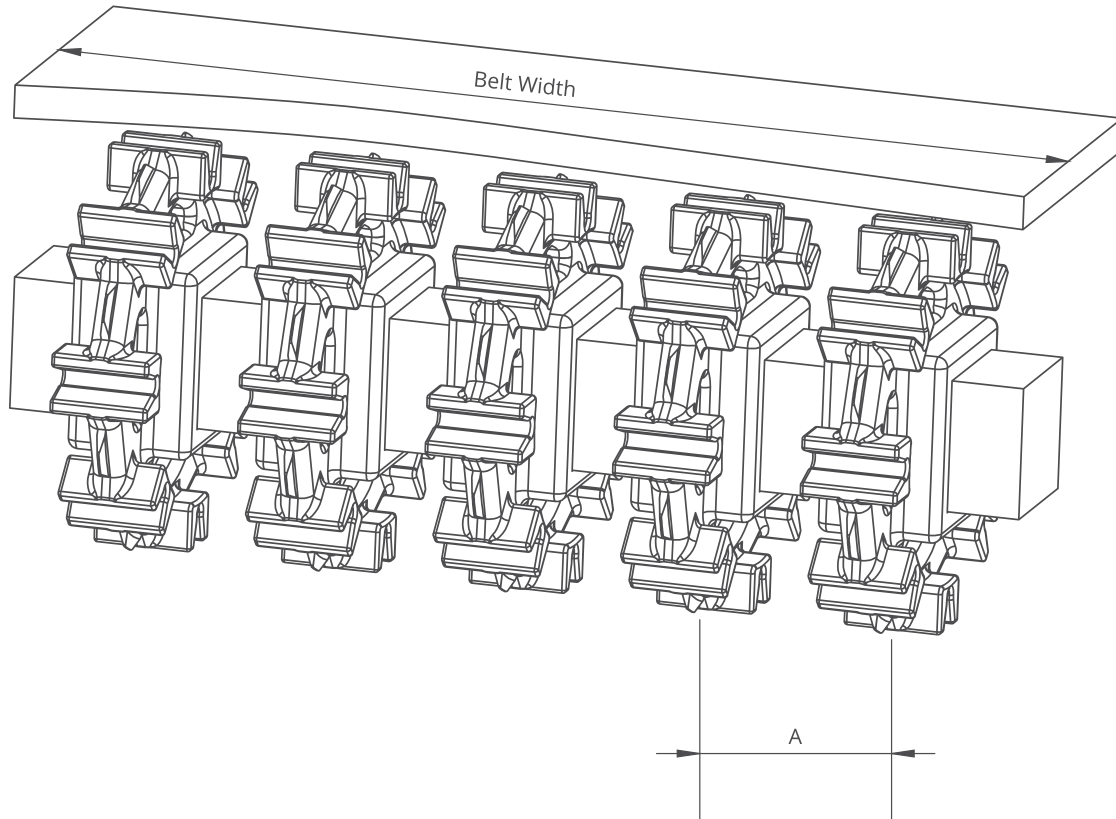

EC508 Series / Sprockets Arrangement

Standard Belt Width		Number of sprockets per shaft		A (mm/inch)	
mm	inch	Drive Shaft	Return Shaft	Min.	Max.
200,0	7.9	2	2	60/2.36	150/5.9
300,0	11.8	3	2	60/2.36	150/5.9
400,0	15.7	3	3	60/2.36	150/5.9
500,0	19.7	4	3	60/2.36	150/5.9
600,0	23.6	4	3	60/2.36	150/5.9
700,0	27.6	5	4	60/2.36	150/5.9
800,0	31.5	6	4	60/2.36	150/5.9
900,0	35.4	6	5	60/2.36	150/5.9
1000,0	39.4	7	5	60/2.36	150/5.9
1100,0	43.3	7	5	60/2.36	150/5.9
1200,0	47.2	8	6	60/2.36	150/5.9
1400,0	55.1	9	7	60/2.36	150/5.9
1600,0	63.0	10	7	60/2.36	150/5.9
1800,0	70.9	11	8	60/2.36	150/5.9
2000,0	78.7	12	8	60/2.36	150/5.9
2200,0	86.6	13	9	60/2.36	150/5.9
2400,0	94.5	14	10	60/2.36	150/5.9
2600,0	102.4	15	10	60/2.36	150/5.9
2800,0	110.2	16	11	60/2.36	150/5.9
3000,0	118.1	17	12	60/2.36	150/5.9

Note: Number of sprockets depends on the belt load.