



EC254 R

Modular Radius Belt Series

- **Meat Applications**

Spiral Freezer

- **Poultry Applications**

Spiral Freezer

- **Seafood Applications**

Freezing Lines, Spiral

- **Bakery Applications**

Spiral, Proofing, Cooling, Freezing Lines, Pan Handling

- **Fruits and Vegetables Applications**

Container Conveyence

- **Automotive Applications**

Car Part Manufacturing, Battery Filling

- **Packaging Applications**

Tray Packers, Box Transport Horizontal



EC254 R

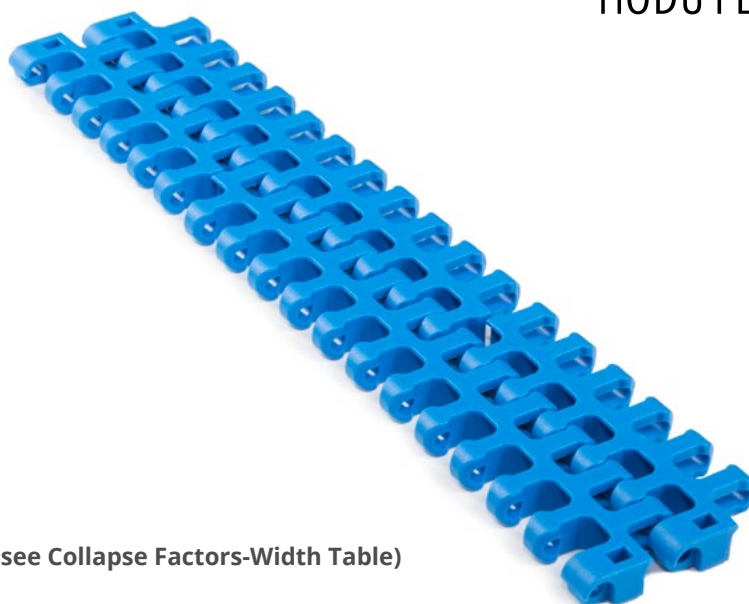

Pitch :	25,8 mm / 1 inch
Belt Surface :	Open, Smooth Surface
Minimum Width :	100 mm / 3.94 inch
Open Area (%) :	36%. (Biggest opening 7,5 x 12 mm)
Flight :	Yes. (T25, T50)
Side Wall :	Yes. (h=25 mm)
Rod :	Ø5 mm / 0.197 inch - Self Lock
Approved :	FDA and EU
Curve :	Yes
Color :	Additional colors available
Cleanability :	Excellent
Application :	Straight and side flexing
Collapse Factor :	2.1 - 2.4 (Please check page 157 to see Collapse Factors-Width Table)
Belt Thickness:	11 mm / 0.433 inch

Product Features and Functional Benefits

- Available for light and medium load capacity.
- 180 degree high speed side flexing applications.
- High temperature and wear resistance.
- Unique locking system.
- Belt provides optimal open area for drainage and airflow.

Available Moulded Module Sizes

- 200 mm / **7.87 inch** module
- 100 mm / **3.94 inch** module

EC254 R / Technical Information

BELT MATERIAL	BELT STRENGTH				TEMPERATURE		BELT WEIGHT
	Straight		Curve		°C (min.) - °F (min.)	°C (max.) - °F (max.)	Kg/m ² - lb/ft ²
	N/m	lb/ft	N/m	lb/ft			
Polypropylene	20900	1430	1100	248	+5 / +42.8	+90 / +194	4,7 - 0.96
Polyethylene	-	-	-	-	-	-	-
Acetal	29700	2035	1650	372	-43 / -45.4	+110 / +230	7,0 - 1.44

- Belt strength and temperature values are maximum on the table.

EC254 R / Standard Belt Widths

BELT SERIES	WIDTH (W)				Belt With Tolerance (max.)
	PP		POM		
	mm	inch	mm	inch	
EC254 R	100,0	4.0	100,0	4.0	± 0,5 mm
EC254 R	150,0	6.0	150,0	6.0	± 0,5 mm
EC254 R	200,0	8.0	200,0	8.0	± 2 mm
EC254 R	250,0	10.0	250,0	10.0	± 2 mm
EC254 R	300,0	12.0	300,0	12.0	± 3 mm
EC254 R	350,0	14.0	350,0	14.0	± 3 mm
EC254 R	400,0	16.0	400,0	16.0	± 3 mm
EC254 R	450,0	18.0	450,0	18.0	± 3 mm
EC254 R	500,0	20.0	500,0	20.0	± 4 mm
EC254 R	550,0	22.0	550,0	22.0	± 4 mm
EC254 R	600,0	24.0	600,0	24.0	± 4 mm
EC254 R	650,0	26.0	650,0	26.0	± 4 mm
EC254 R	700,0	28.0	700,0	28.0	± 4 mm
EC254 R	750,0	30.0	750,0	30.0	± 4 mm
EC254 R	800,0	32.0	800,0	32.0	± 4 mm

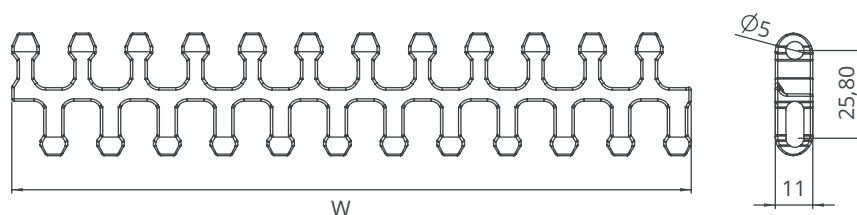

- Standard belt increments 50 mm.
- Non-standard increments 16,6 mm
- Please contact with customer service for precise belt measurements.
- For bigger sizes, please contact with customer service.

EC254 R Series Sprockets and Technical Specifications



Z15



Z8

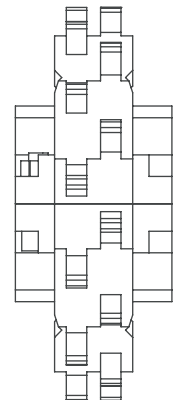
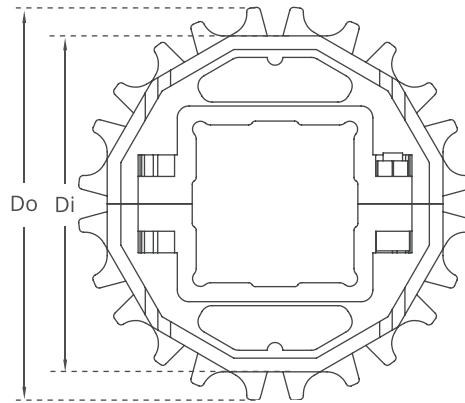
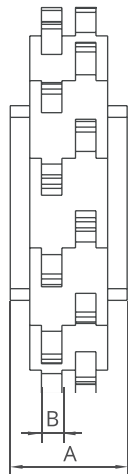
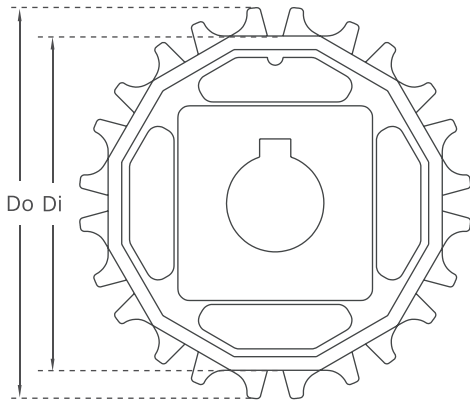

Split moulded sprockets are available.

EC254 R Series / Standard Sprockets Dimensions

NO. TEETH	Di mm/inch	Do mm/inch	B mm/inch	A mm/inch	Square Bore (Q) mm/inch	Round Bore (R) mm/inch	PRODUCT CODE	
							Square Type (Q)	Round Type (R)
Z8	52,0 / 2.05	67,0 / 2.64	6 / 0.24	30 / 1.18	25 / 1	25 / 1	MD-TR254SQ25Z8*POM	MD-TR254SRZ8*POM
Z10	69,0 / 2.72	84,0 / 3.31	6 / 0.24	30 / 1.18	40 / 1.5	25-30 / 1-1.25	MD-TR254SQZ10*POM	MD-TR254SRZ10*POM
Z12	85,84 / 3.38	100,84 / 3.97	6 / 0.24	30 / 1.18	40 / 1.5	25-30 / 1-1.25	MD-TR254SQZ12*POM	MD-TR254SRZ12*POM
Z15	110,8 / 4.36	125,8 / 4.95	6 / 0.24	30 / 1.18	40 / 1.5	25-30 / 1-1.25	MD-TR254SQZ15*POM	MD-TR254SRZ15*POM
Z16	119,1 / 4.69	134,1 / 5.28	6 / 0.24	30 / 1.18	40 / 1.5	25-30 / 1-1.25	MD-TR254SQZ16*POM	MD-TR254SRZ16*POM
Z18	135,63 / 5.34	150,58 / 5.93	6 / 0.24	30 / 1.18	40 / 1.5	25-30 / 1-1.25	MD-TR254SQZ18*POM	MD-TR254SRZ18*POM

*Other sprockets and hub sizes are manufactured up to request. *PA (Polyamide) and PP (Polypropylene) sprockets raw material is available on request.

***Machined Split Sprockets are available for each size.**



Clamp



Machined Split Sprocket

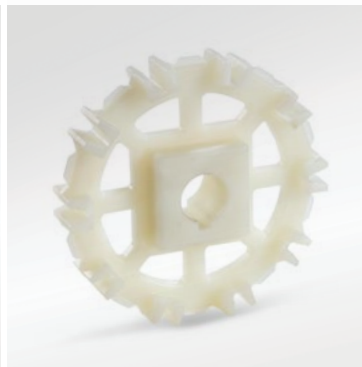

Moulded Sprocket

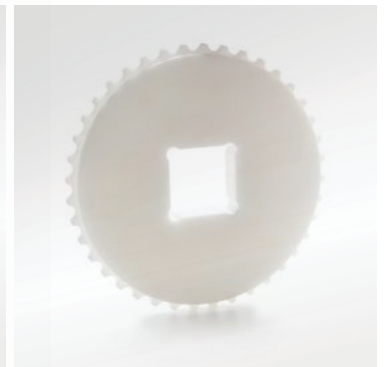

Machined Sprocket

EC254 R Series *Accessories and Technical Specifications*



MODUTECH

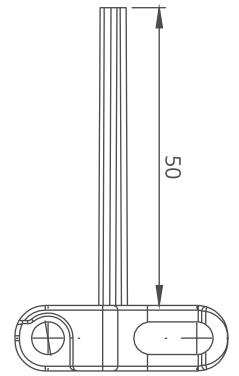
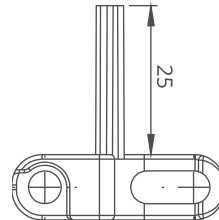

EC254 R Series / TAB - Technical Specification

TAB-M

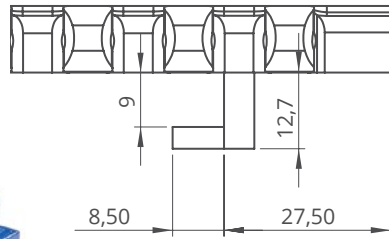

TAB-E

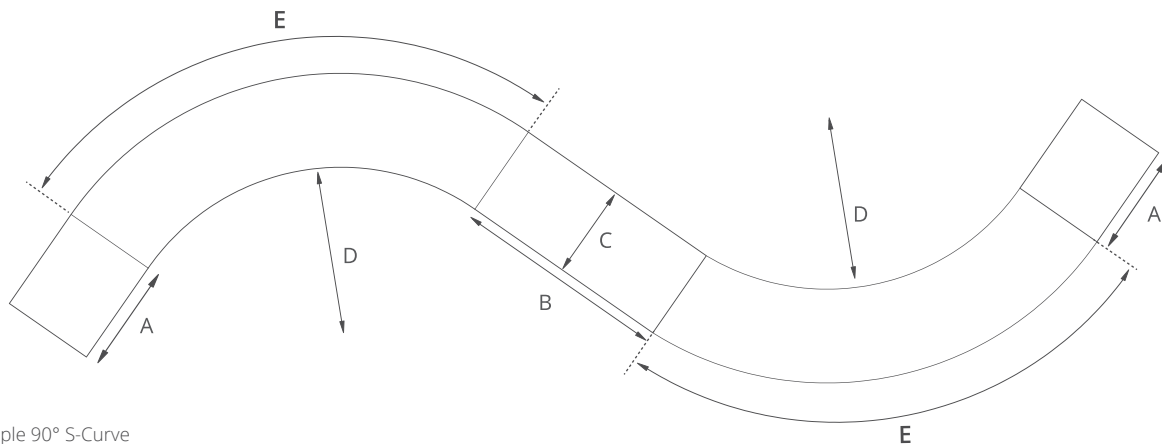
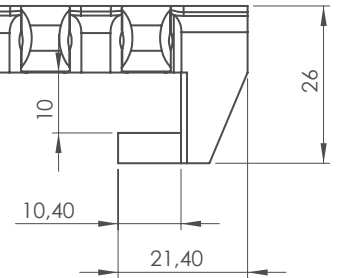

Radius Belt Example 90° S-Curve

EC254 R Series / Radius Belt Calculation

- A: Straight run pull and n = Belt width
- B: Straight run between 2 curves = min. 2 x belt width
- C: Belt width
- D: Minimum inner radius
- E: Curve length

$$\text{Collapse Factor} = \frac{\text{Min. inner radius}}{\text{Belt width}}$$

$$\text{Minimum inner radius} = \text{Collapse Factor} \times \text{Belt width}$$

CALCULATION EXAMPLE

Belt width: 400 mm 90° Radius Belt
Collapse Factor: 2.14

$$D: 400 \times 2.14 = 856 \text{ mm}$$

$$A: 400 \text{ (Min.)}$$

$$B: 2 \times 400 = 800 \text{ mm (Min.)}$$

$$E: \frac{2 \times (C+D) \times 3.14}{4} = 1972 \text{ mm}$$

$$\text{Total length} = (2 \times A) + B + (2 \times E)$$

EC254 R Series *Engineering Information*

A - ± 0,031" (1mm) C - ± (Max.)
 B - ± 0,125" (3mm) E - ± (Min.)

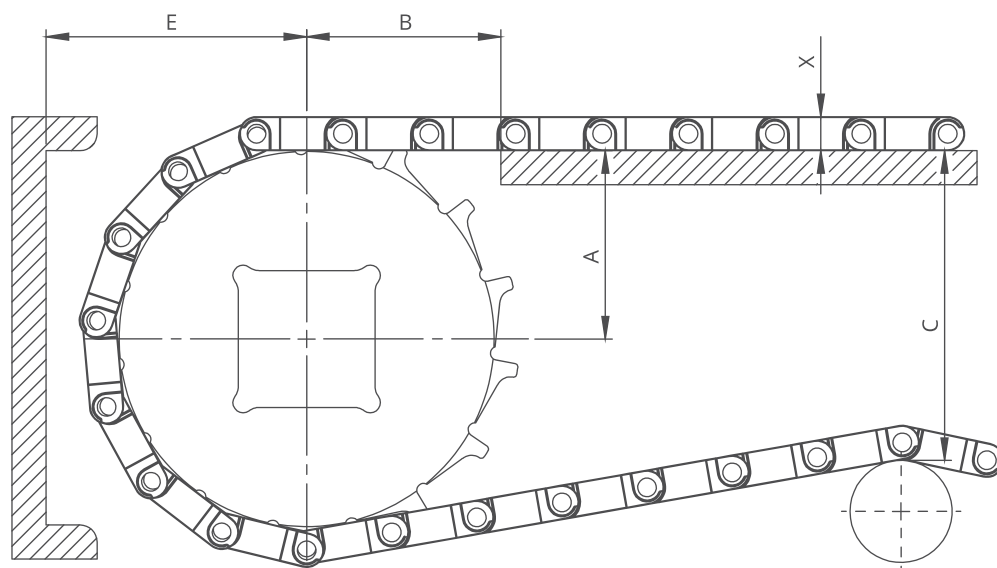

EC254 R Series / Conveyor Frame Dimensions

Sprockets Description			A		B		C		E		X	
Pitch Diameter		No.Teeth	Range (Bottom to Top)		inch	mm	inch	mm	inch	mm	inch	mm
inch	mm		inch	mm								
EC254 R												
2.38	60,5	8	1.15	29,2	1.55	39,4	1.95	49,5	1.94	49,2	0.43	11,0
3.07	78,0	10	1.46	37,1	1.77	45,0	2.60	66,1	2.25	57,1	0.43	11,0
3.74	95,0	12	1.76	44,8	1.97	50,1	3.24	82,3	2.55	64,8	0.43	11,0
4.70	119,5	15	2.22	56,4	2.23	56,7	4.18	106,1	3.01	76,4	0.43	11,0
5.02	127,5	16	2.37	60,2	2.38	60,5	4.46	113,2	3.21	81,5	0.43	11,0
5.71	145,0	18	2.73	69,3	2.45	62,3	5.19	131,8	3.51	89,3	0.43	11,0
EC254 R-GT												
2.38	60,5	8	1.15	29,2	1.55	39,4	1.95	49,5	2.18	53,7	0.61	15,5
3.07	78,0	10	1.46	37,1	1.77	45,0	2.60	66,1	2.48	61,6	0.61	15,5
3.74	95,0	12	1.76	44,8	1.97	50,1	3.24	82,3	2.79	69,3	0.61	15,5
4.70	119,5	15	2.22	56,4	2.23	56,7	4.18	106,1	3.25	80,9	0.61	15,5
5.02	127,5	16	2.37	60,2	2.38	60,5	4.46	113,2	3.46	86,0	0.61	15,5
5.71	145,0	18	2.73	69,3	2.45	62,3	5.19	131,8	3.76	93,8	0.61	15,5

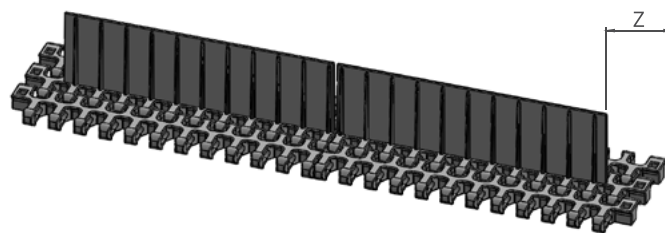
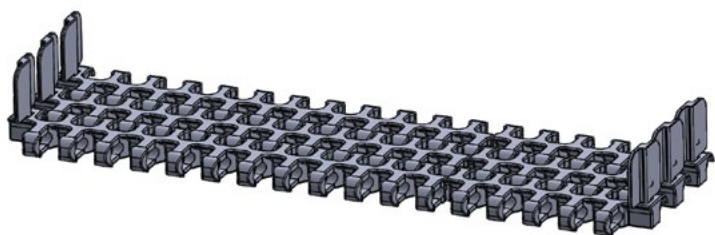

EC254 R Series / Sidewall Technical Specifications

Possible Sidewall Indents	-	
	mm	inch
Standard, no module cutting	-	-

EC254 R Series / Flight Technical Specifications

Possible Flight Indents for EC254 R Series	Z	
	mm	inch
Standard, no module cutting	25,0	0.98
Standard, module cutting	37,5	1.48
Standard, module cutting	54,3	2.14



EC254 R Series *Engineering Information*

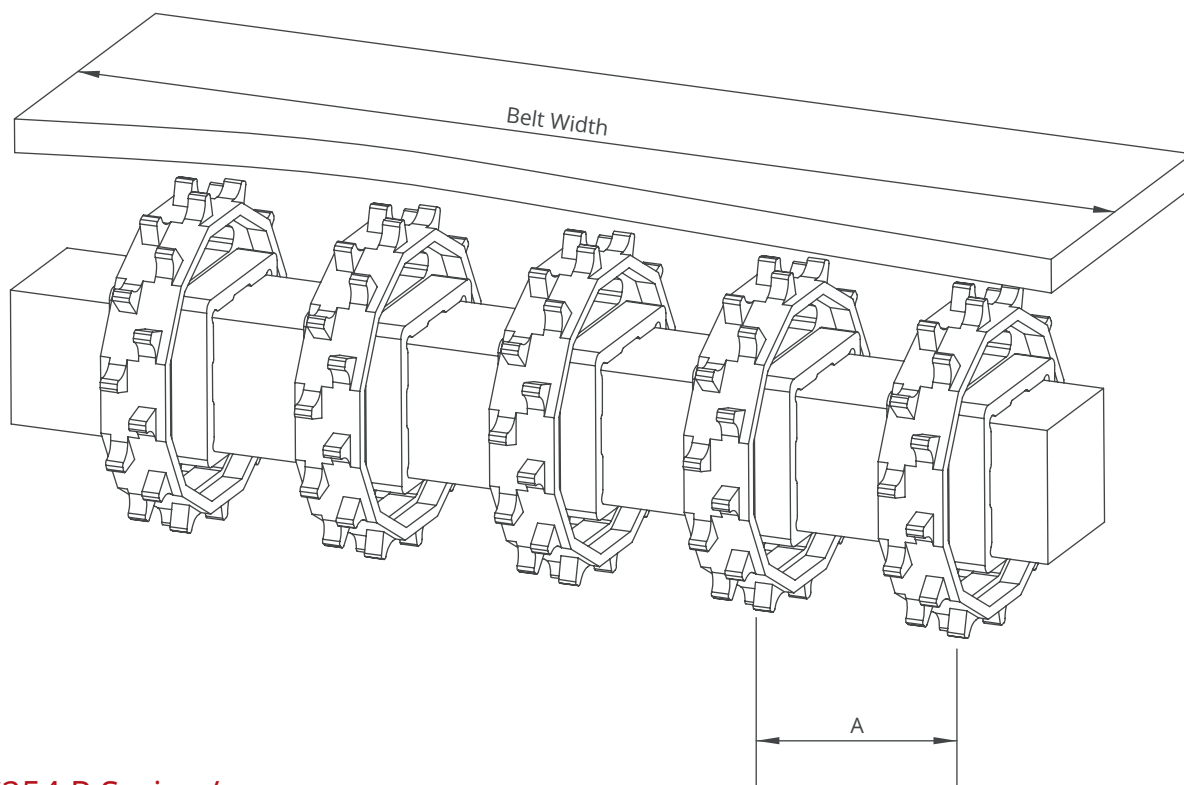

EC254 R Series / Sprockets Arrangement

Standard Belt Width		Number of sprockets per shaft		A (mm/inch)	
mm	inch	Drive Shaft	Return Shaft	Min.	Max.
150,0	6.0	2	2	50/2	120/4.7
200,0	8.0	2	2	50/2	120/4.7
250,0	10.0	3	2	50/2	120/4.7
300,0	12.0	3	2	50/2	120/4.7
350,0	14.0	3	3	50/2	120/4.7
400,0	16.0	4	3	50/2	120/4.7
450,0	18.0	4	3	50/2	120/4.7
500,0	20.0	5	4	50/2	120/4.7
550,0	22.0	5	4	50/2	120/4.7
600,0	24.0	6	5	50/2	120/4.7
700,0	26.0	7	5	50/2	120/4.7
800,0	28.0	8	6	50/2	120/4.7
900,0	30.0	9	7	50/2	120/4.7
1000,0	32.0	10	7	50/2	120/4.7

Note: Number of sprockets depends on the belt load.

EC254 R Series / Collapse Factors per widths for EC254 R Serie

Nom. Belt Width (mm)	250,0	300,0	350,0	400,0	450,0	500,0	550,0	600,0	650,0	700,0	750,0	800,0	850,0	900,0	950,0	1000,0	1050,0	1100,0	1150,0	1200,0
Nom. Belt Width (inch)	10.0	12.0	14.0	16.0	18.0	20.0	22.0	24.0	26.0	28.0	30.0	32.0	34.0	36.0	38.0	40.0	42.0	44.0	46.0	48.0
Collapse Factor	2,07	2,10	2,12	2,14	2,15	2,16	2,17	2,18	2,18	2,19	2,19	2,19	2,20	2,20	2,20	2,21	2,21	2,21	2,21	2,21
Min. Inner Radius (mm)	517,5	630,0	742,0	856,0	967,5	1080,0	1193,5	1308,0	1417,0	1533,0	1642,5	1752,0	1870,0	1980,0	2090,0	2210,0	2320,5	2431,0	2541,5	2652,0
Min. Inner Radius (inch)	20.7	25.2	29.7	34.2	38.7	43.2	47.7	52.3	56.7	61.3	65.7	70.8	74.8	79.2	83.6	88.4	92.8	97.2	101.7	106.1

Standard range of belt width and collapse factor (Min. Inner radius = Collapse factor x Standard belt width)