



EC127 FG

Modular Belt Series

- Bakery Applications

Divider, Oven Infeed - Outfeed, Cooling Lines, Coating Lines, Glazing Lines

- Poultry Applications

Breeding Lines and Grading Lines, Weighing Lines

- Seafood Applications

Breeding Lines, Grading Lines and Weighing Lines

- Snack Food Applications

Cooling Lines

- Fruits and Vegetables Applications

Draining, Sterilization, Conveyance

- Packaging Applications

Check Weighers, Filling, Palletizing - Depalletizing, Box Transfer



EC127 FG

Pitch:	12,7 mm / 0.5 inch
Belt Surface:	Open, Smooth Surface
Minimum Width:	50 mm / 1.97 inch
Open Area (%):	20%. (Biggest opening 3 x 6 mm)
Flight:	Yes (T25, T50)
Sidewall:	No
Rod:	Ø4,7 mm / 0.185 inch - Self Lock
Approved:	FDA and EU
Curve:	No
Color:	Additional colors available
Cleanability:	Excellent
Belt Thickness:	10 mm / 0.394 inch



Product Features and Functional Benefits

- Belt provides optimal open area for drainage and airflow.
- Less friction and product contact for easy cooking, cooling and freezing of products.
- Reduced dirt and oxide build due to self cleaning surface.

Available Moulded Module Sizes

- 150 mm / **5.90 inch** module
- 100 mm / **3.94 inch** module
- 50 mm / **1.97 inch** module

EC127 FG / Technical Information

BELT MATERIAL	BELT STRENGTH				TEMPERATURE		BELT WEIGHT
	Straight		Curve		°C / °F (min.)	°C/°F (max.)	Kg/m ² / lb/ft ²
	N/m	lb/ft	N/m	lb/ft			
Polypropylene	12100	825	-	-	+5 / +41	+90 / +194	5,2 / 1.07
Polyethylene	6600	452	-	-	-73 / -99.4	+66 / +150.8	5,4 / 1.11
Acetal	19800	1356	-	-	-43 / -45.4	+110 / +230	7,2 / 1.48

- Belt strength and temperature values are maximum on the table.

EC127 FG / Standard Belt Widths

BELT SERIES	WIDTH (W)				Belt With Tolerance (max.)
	PP-PE		POM		
	mm	inch	mm	inch	
EC127 FG	150,0	5.90	150,0	5.90	± 1 mm
EC127 FG	200,0	7.87	200,0	7.87	± 1 mm
EC127 FG	250,0	9.84	250,0	9.84	± 2 mm
EC127 FG	300,0	11.81	300,0	11.81	± 2 mm
EC127 FG	350,0	13.77	350,0	13.77	± 2 mm
EC127 FG	400,0	15.75	400,0	15.75	± 2 mm
EC127 FG	450,0	17.71	450,0	17.71	± 2 mm
EC127 FG	500,0	19.69	500,0	19.69	± 2 mm
EC127 FG	550,0	21.65	550,0	21.65	± 2 mm
EC127 FG	600,0	23.62	600,0	23.62	± 3 mm
EC127 FG	650,0	25.60	650,0	25.60	± 3 mm
EC127 FG	700,0	27.56	700,0	27.56	± 3 mm
EC127 FG	750,0	29.50	750,0	29.50	± 3 mm
EC127 FG	800,0	31.50	800,0	31.50	± 3 mm
EC127 FG	850,0	33.46	850,0	33.46	± 4 mm
EC127 FG	900,0	35.43	900,0	35.43	± 4 mm

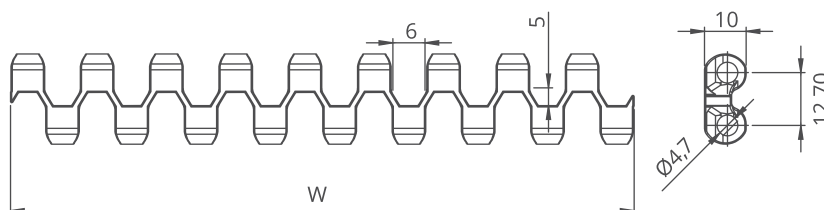

- Standard belt increments 50 mm.
- Non-standard belt increments 16,6 mm.
- Please contact with customer service for precise belt measurements.

EC127 Series Sprockets and Technical Specifications



Z24



Z24

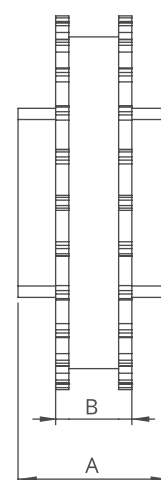
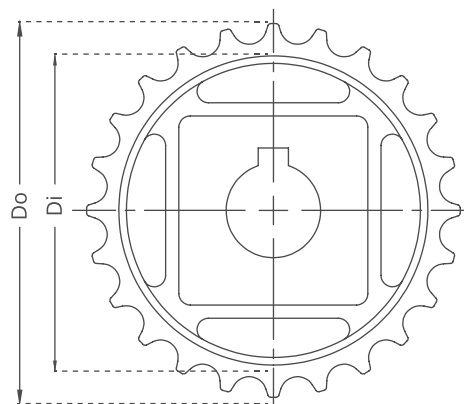
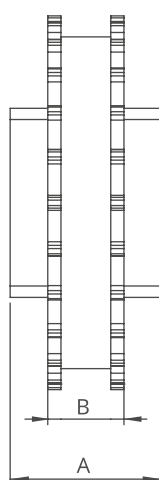
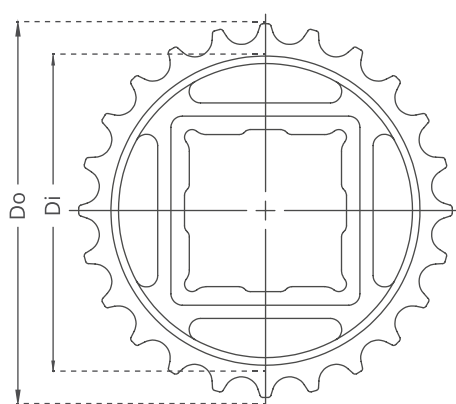

EC127 Series / Standard Moulded Sprockets Dimensions

NO. TEETH	Di mm/inch	Do mm/inch	B mm/inch	A mm/inch	Square Bore (Q) mm/inch	Round Bore (R) mm/inch	PRODUCT CODE	
							Square Type (Q)	Round Type (R)
Z19	68,5 / 2.69	78,0 / 2.54	20 / 0.79	40 / 1.57	25-40 / 1-1.5	25-30 / 1-1.25	EC127SQZ19*PA	EC127SRZ19*PA
Z24	88,7 / 3.49	98,8 / 3.89	20 / 0.79	40 / 1.57	25-40 / 1-1.5	25-30 / 1-1.25	EC127SQZ24*PA	EC127SRZ24*PA
Z28	105,0 / 4.13	115,2 / 4.53	20 / 0.79	40 / 1.57	25-40 / 1-1.5	25-30 / 1-1.25	EC127SQZ28*PA	EC127SRZ28*PA
Z30	113,0 / 4.44	123,3 / 4.85	20 / 0.79	40 / 1.57	25-40 / 1-1.5	25-30 / 1-1.25	EC127SQZ30*PA	EC127SRZ30*PA
Z36	137,5 / 5.41	148,0 / 5.82	20 / 0.79	40 / 1.57	25-40 / 1-1.5	25-30 / 1-1.25	EC127SQZ36*PA	EC127SRZ36*PA

*Other sprockets and hub sizes are manufactured up to request.

*POM (Acetal) and PP (Polypropylene) sprockets raw material is available on request.

***Machined Split Sprockets are available for each size.**



Clamp



Machined Split Sprocket

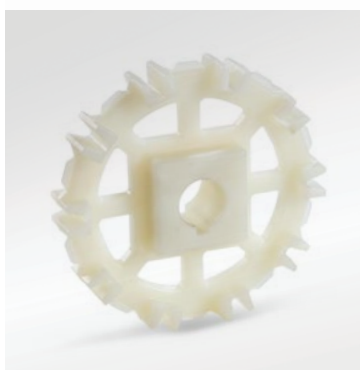

Moulded Sprocket

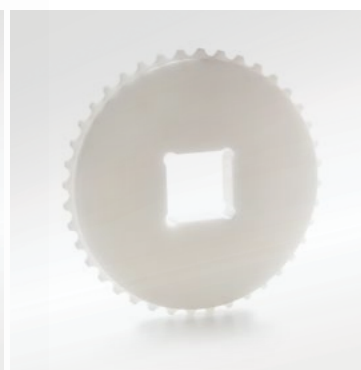

Machined Sprocket

EC127 Series *Accessories and Technical Specifications*

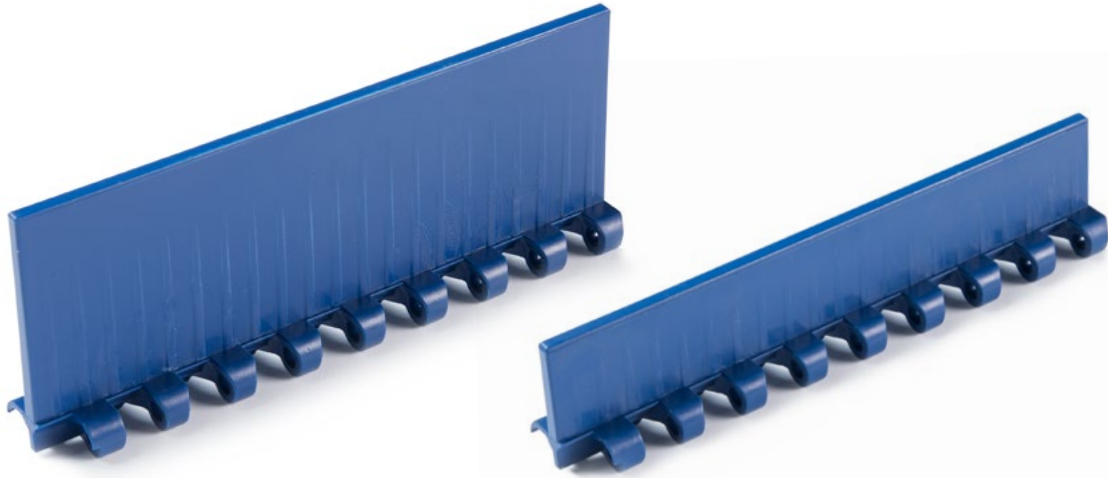

EC127 Series / Flight Dimensions

EC127 Series / Flights				
PRODUCT CODE	Flight Height (mm/ inch)	Flight Width (mm/ inch)	PRODUCT CODE	Sidewall Height (mm/ inch)
EC127T25	25 / 1	150 / 5.90	-	-
EC127T50	50 / 2	150 / 5.90	-	-

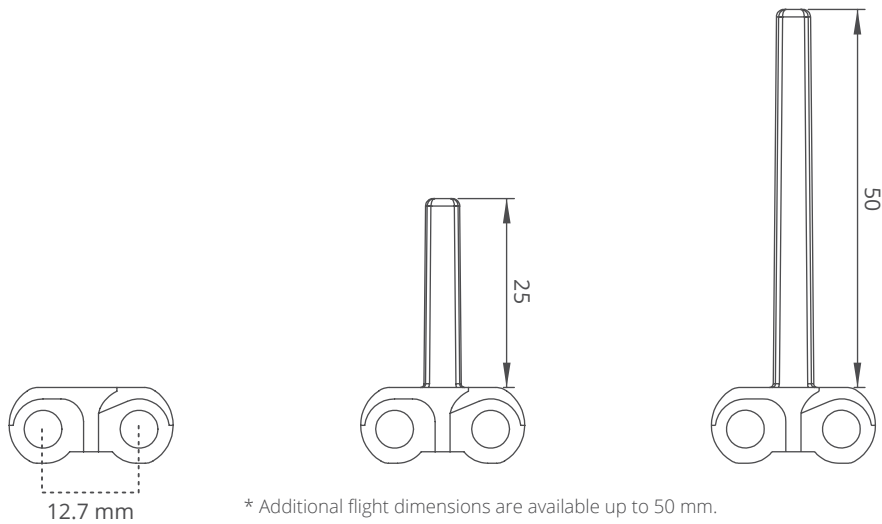

* Additional flight dimensions are available up to 50 mm.

EC127 Series / Flight Technical Specifications

Possible Flight Indents for EC127 Series	Z	
	mm	inch
Standard, module cutting	33,3	1.31
Standard, no module cutting	50,0	1.97
Standard, module cutting	66,6	2.62
Standard, module cutting	83,3	3.28
Standard, no module cutting	100,0	3.94

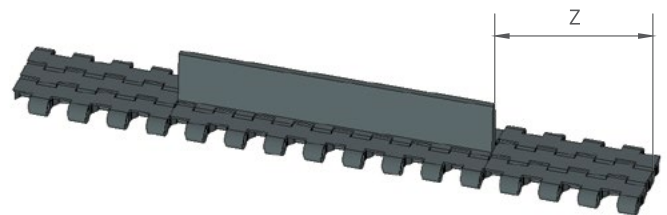

*Non-standard flight indent is on request.

EC127 Series *Engineering Information*

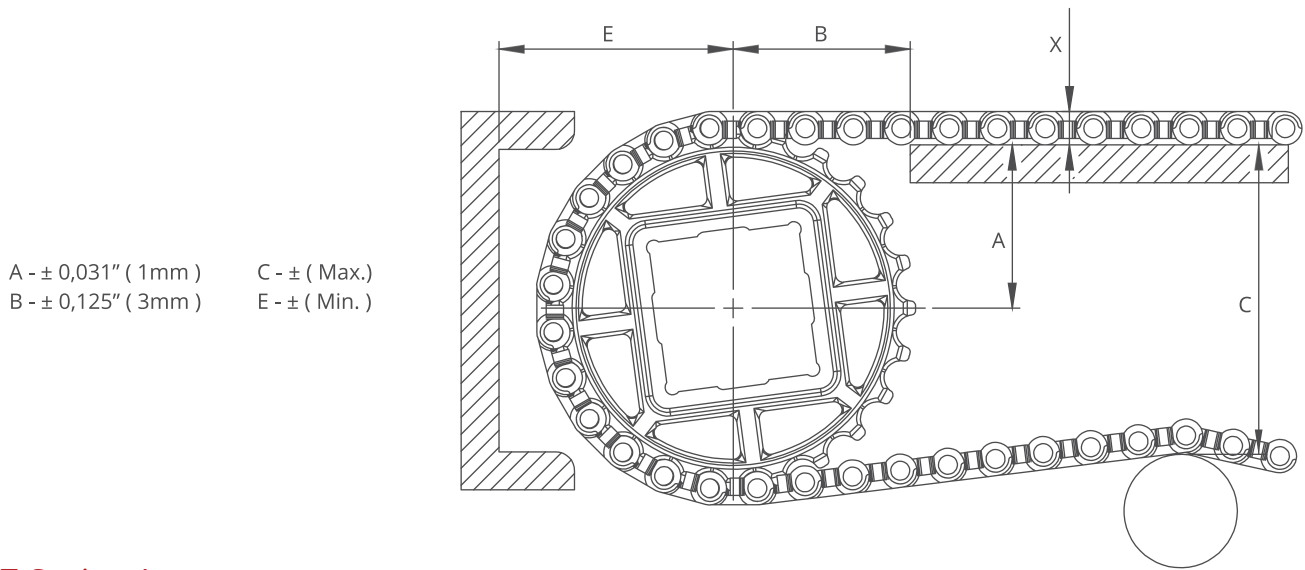

EC127 Series / Conveyor Frame Dimensions

Sprockets Description			A		B		C		E		X	
Pitch Diameter		No.Teeth	Range (Bottom to Top)		inch	mm	inch	mm	inch	mm	inch	mm
inch	mm		inch	mm								
EC127 C, EC127 FG												
2.89	73,4	19	1.36	34,5	1.67	42,5	2.83	72,0	2.09	53,0	0.39	10,0
3.69	93,8	24	1.73	44,0	1.89	48,0	3.23	82,0	2.48	63,0	0.39	10,0
4.33	110,1	28	2.07	52,5	2.05	52,0	3.86	98,0	2.80	71,0	0.39	10,0
4.66	118,3	30	2.24	57,0	2.13	54,0	4.02	102,0	2.95	75,0	0.39	10,0
5.62	142,7	36	2.72	69,0	2.35	59,8	4.96	126,0	3.43	87,0	0.39	10,0
EC127 GT												
2.89	73,4	19	1.46	37,0	1.67	42,5	2.83	72,0	2.19	55,5	0.49	12,5
3.69	93,8	24	1.83	46,5	1.89	48,0	3.23	82,0	2.58	65,5	0.49	12,5
4.33	110,1	28	2.17	55,0	2.05	52,0	3.86	98,0	2.89	73,5	0.49	12,5
4.66	118,3	30	2.34	59,5	2.13	54,0	4.02	102,0	3.05	77,5	0.49	12,5
5.62	142,7	36	2.81	71,5	2.35	59,8	4.96	126,0	3.52	89,5	0.49	12,5

EC127 Series / Slider Support System For Straight Running Belts

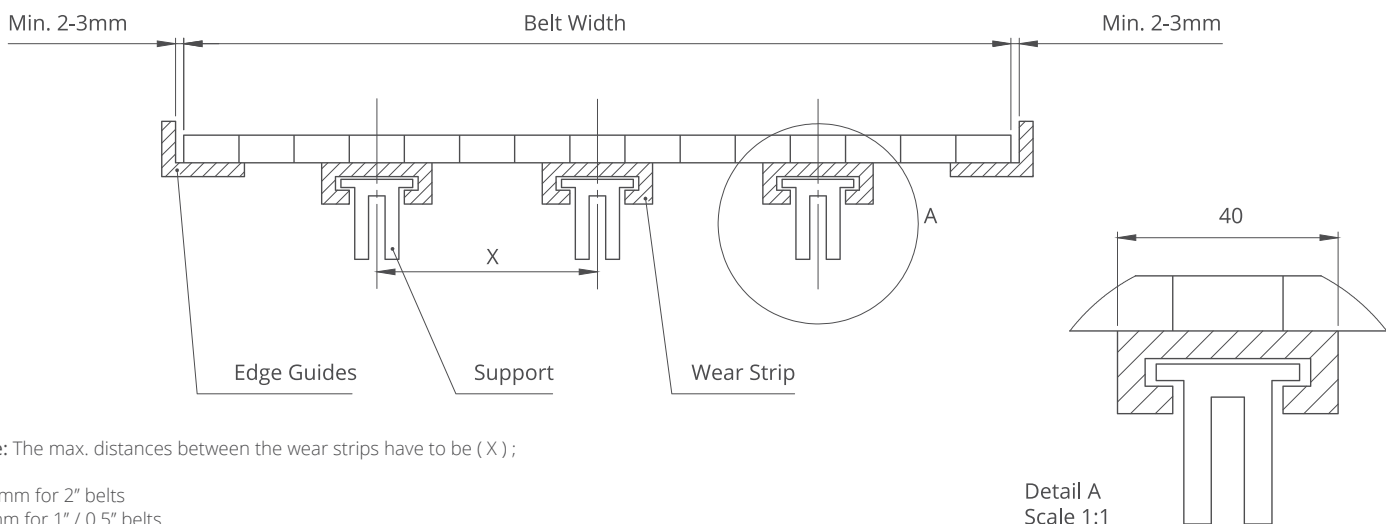

Note: The max. distances between the wear strips have to be (X) ;

125 mm for 2" belts
 80 mm for 1" / 0.5" belts

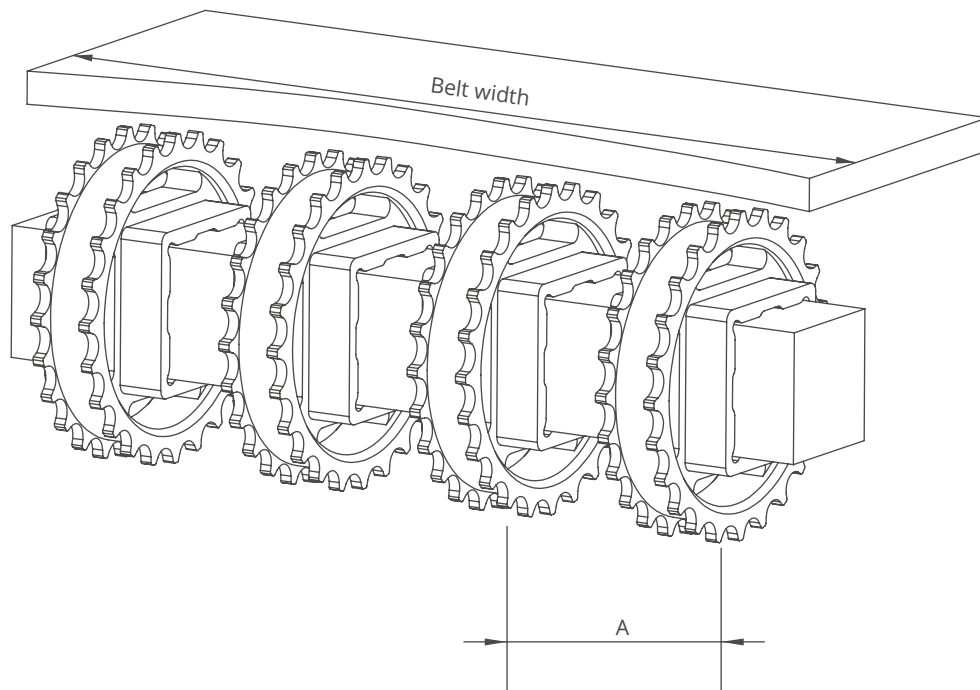

EC127 Series / Sprockets Arrangement

Standard Belt Width		Number of sprockets per shaft		A (mm/inch)	
mm	inch	Drive Shaft	Return Shaft	Min.	Max.
150,0	5.91	2	2	50/2	100/4
200,0	7.87	3	2	50/2	100/4
250,0	9.84	3	2	50/2	100/4
300,0	11.81	4	3	50/2	100/4
350,0	13.78	4	3	50/2	100/4
400,0	15.75	5	3	50/2	100/4
450,0	17.72	5	3	50/2	100/4
500,0	19.69	6	4	50/2	100/4
550,0	21.65	7	4	50/2	100/4
600,0	23.62	7	4	50/2	100/4
650,0	25.59	7	4	50/2	100/4
700,0	27.56	8	5	50/2	100/4
750,0	29.53	9	6	50/2	100/4
800,0	31.50	9	6	50/2	100/4
850,0	33.46	10	7	50/2	100/4
900,0	35.43	11	7	50/2	100/4
950,0	37.40	11	7	50/2	100/4
1000,0	39.37	11	7	50/2	100/4
1050,0	41.34	11	7	50/2	100/4
1100,0	43.31	12	7	50/2	100/4
1150,0	45.28	12	7	50/2	100/4
1200,0	47.24	12	7	50/2	100/4
1250,0	49.21	13	8	50/2	100/4
1300,0	51.18	13	8	50/2	100/4
1350,0	53.15	13	8	50/2	100/4
1400,0	55.12	14	8	50/2	100/4