



MD254 FG

Modular Belt Series

• Bakery Applications

Oven Infeed - Outfeed, Cooling Lines, Coating Lines, Glazing Lines, Freezing Lines, Conditioning Lines

• Poultry Applications

Skinning, Breeding Machines and Grading Lines

• Seafood Applications

Breeding Machines, Draining Lines, Glazing Lines, Elevators, Freezing Lines

• Snack Food Applications

Proofer Lines, Boiler Infeed, Oven Infeed - Outfeed, Cooling Lines

• Fruits and Vegetables Applications

Prewashing - Rinsing, Draining, Blanching Lines, Elevators

• Packaging Applications

Filling, Accumulation Palletizing - Depalletizing, Box Transfer

• Textile Applications

Cutter, Dyeing



MD254 FG



Pitch:	25,4 mm / 1 inch
Belt Surface:	Open, Smooth Surface
Minimum Width:	50 mm / 1.97 inch
Open Area (%):	33%. (Biggest opening 5,5 x 7 mm)
Flight:	Yes (T25, T50, TC50, TCH50, TNC75, TNC100, T75, T100)
Sidewall:	Yes (h=25mm, h=50mm, h=75mm, h=100mm)
Rod:	Ø 5 mm / 0.197 inch - Self Lock
Approved:	FDA and EU
Curve:	No
Color:	Additional colors available
Cleanability:	Good
Belt Thickness:	10 mm / 0.394 inch

Product Features and Functional Benefits

- Belt provides optimal open area for drainage and airflow.
- Less friction and product contact for easy cooking, cooling and freezing of products.
- Reduced dirt and oxide build due to self cleaning surface.
- Bi-directional belt for long conveyors.
- Stainless steel pins option for high temperature applications.
- Easy to clean reduces downtime for cleaning time 70%.
- Stainless steel pins option reduce belt elongation for high temperature application.

Available Moulded Module Sizes

- 200 mm / **7.87 inch** module
- 100 mm / **3.94 inch** module
- 50 mm / **1.97 inch** module
- 33 mm / **1.30 inch** module

MD254 FG / Technical Information

BELT MATERIAL	BELT STRENGTH				TEMPERATURE		BELT WEIGHT
	Straight		Curve		°C / °F (min.)	°C / °F (max.)	Kg/m ² / lb/ft ²
	N/m	lb/ft	N/m	lb/ft			
Polypropylene	15400	1055	-	-	+5 / +41	+90 / +194	4,6 / 0.94
Polyethylene	8800	603	-	-	-73 / -99.4	+66 / +150.8	5,1 / 1.04
Acetal	27170	1861	-	-	-43 / -45.4	+110 / +230	7,1 / 1.45

- Belt strength and temperature values are maximum on the table.

MD254 FG / Standard Belt Widths

BELT SERIES	WIDTH (W)				Belt With Tolerance (max.)
	PP-PE		POM		
	mm	inch	mm	inch	
MD254 FG	200,0	7.87	200,0	7.87	± 1 mm
MD254 FG	250,0	9.84	250,0	9.84	± 1 mm
MD254 FG	300,0	11.81	300,0	11.81	± 2 mm
MD254 FG	350,0	13.77	350,0	13.77	± 2 mm
MD254 FG	400,0	15.75	400,0	15.75	± 2 mm
MD254 FG	450,0	17.71	450,0	17.71	± 2 mm
MD254 FG	500,0	19.69	500,0	19.69	± 2 mm
MD254 FG	550,0	21.65	550,0	21.65	± 3 mm
MD254 FG	600,0	23.62	600,0	23.62	± 3 mm
MD254 FG	650,0	25.60	650,0	25.60	± 3 mm
MD254 FG	700,0	27.56	700,0	27.56	± 3 mm
MD254 FG	750,0	29.50	750,0	29.50	± 3 mm
MD254 FG	800,0	31.50	800,0	31.50	± 3 mm
MD254 FG	850,0	33.46	850,0	33.46	± 4 mm
MD254 FG	900,0	35.43	900,0	35.43	± 4 mm

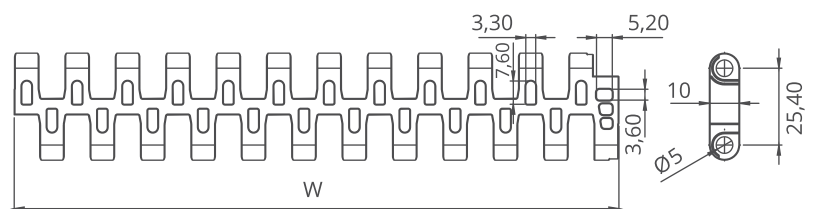

- Standard belt increments 50 mm.
- Non-standard belt increments 16,6 mm.
- Please contact with customer service for precise belt measurements.

MD254 Series Sprockets and Technical Specifications



Z15



Z8

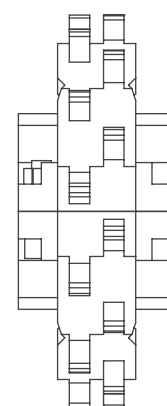
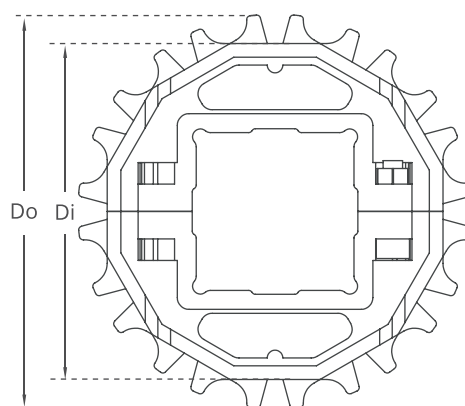
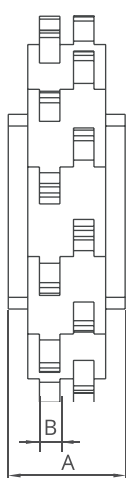
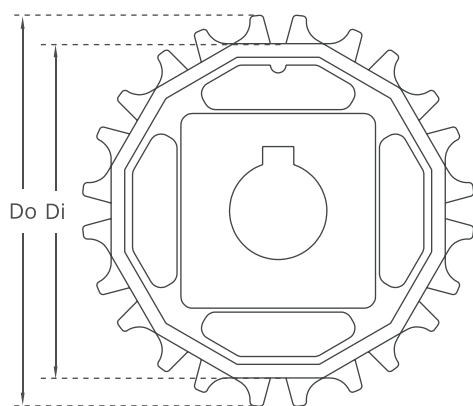

Split moulded sprockets are available.

MD254 Series / Standard Sprockets Dimensions

NO. TEETH	Di mm/inch	Do mm/inch	B mm/inch	A mm/inch	Square Bore (Q) mm/inch	Round Bore (R) mm/inch	PRODUCT CODE	
							Square Type (Q)	Round Type (R)
Z8	52,0 / 2.05	67,0 / 2.64	6 / 0.24	30 / 1.18	25 / 1	25 / 1	MD-TR254SQ25Z8*POM	MD-TR254SRZ8*POM
Z10	69,0 / 2.72	84,0 / 3.31	6 / 0.24	30 / 1.18	40 / 1.5	25-30 / 1-1.25	MD-TR254SQZ10*POM	MD-TR254SRZ10*POM
Z12	85,8 / 3.38	100,8 / 3.97	6 / 0.24	30 / 1.18	40 / 1.5	25-30 / 1-1.25	MD-TR254SQZ12*POM	MD-TR254SRZ12*POM
Z15	110,8 / 4.36	125,8 / 4.95	6 / 0.24	30 / 1.18	40 / 1.5	25-30 / 1-1.25	MD-TR254SQZ15*POM	MD-TR254SRZ15*POM
Z16	119,1 / 4.69	134,1 / 5.28	6 / 0.24	30 / 1.18	40 / 1.5	25-30 / 1-1.25	MD-TR254SQZ16*POM	MD-TR254SRZ16*POM
Z18	135,6 / 5.34	150,6 / 5.93	6 / 0.24	30 / 1.18	40 / 1.5	25-30 / 1-1.25	MD-TR254SQZ18*POM	MD-TR254SRZ18*POM
Z20	150,7 / 5.93	167,3 / 6.59	6 / 0.24	30 / 1.18	40 / 1.5	25-30 / 1-1.25	MD-TR254SQZ20*POM	MD-TR254SRZ20*POM

*Other sprockets and hub sizes are manufactured up to request. *PA (Polyamide) and PP (Polypropylene) sprockets raw material is available on request.

***Machined Split Sprockets are available for each size.**



Clamp



Machined Split Sprocket

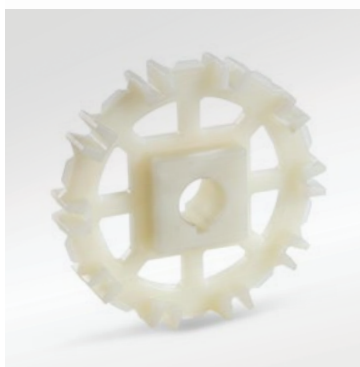

Moulded Sprocket

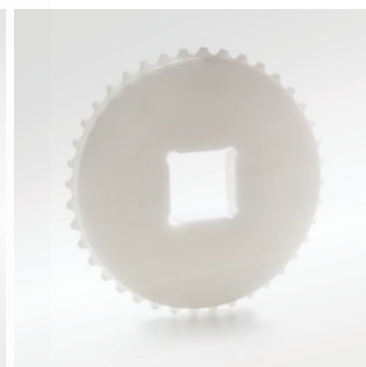

Machined Sprocket



MODUTECH

MD254 Series Accessories and Technical Specifications

No-Cling
TNC
Flight



TCH
Flight

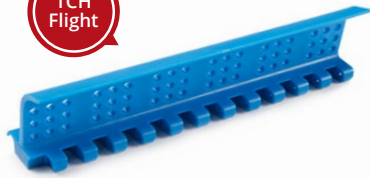

MD254 Series / Flight & Sidewall Dimensions

MD254 Series / Flights & Sidewalls

PRODUCT CODE	Flight Height (mm/ <i>inch</i>)	Flight Width (mm/ <i>inch</i>)	PRODUCT CODE	Sidewall Height (mm/ <i>inch</i>)
MD254T25	25 / 1	200 / 7.87	MD254SW25	25 / 1
MD254T50	50 / 2	200 / 7.87	MD254SW50	50 / 2
MD254T75	75 / 3	200 / 7.87	MD254SW75	75 / 3
MD254T100	100 / 4	200 / 7.87	MD254SW100	100 / 4
MD254TC50	50 / 2	200 / 7.87	-	-
MD254TCH50	50 / 2	200 / 7.87	-	-
MD254TNC75	75 / 3	200 / 7.87	-	-
MD254TNC100	100 / 4	200 / 7.87	-	-

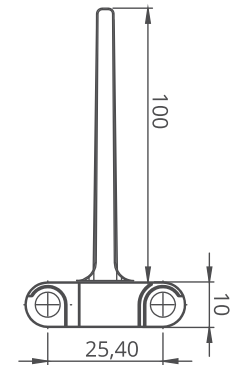
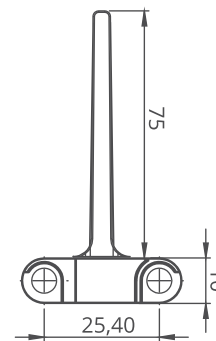
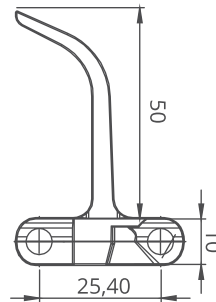
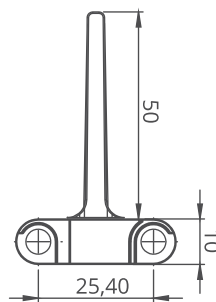
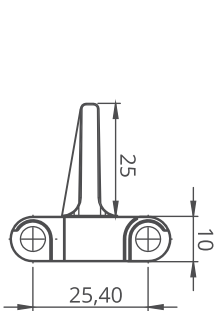

* Additional flight dimensions are available up to 100 mm.

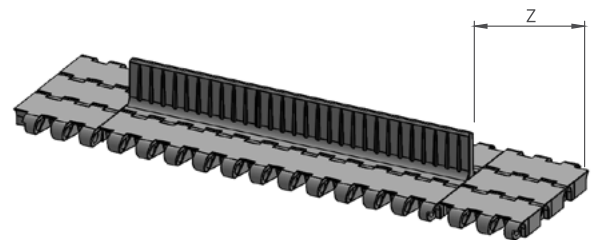
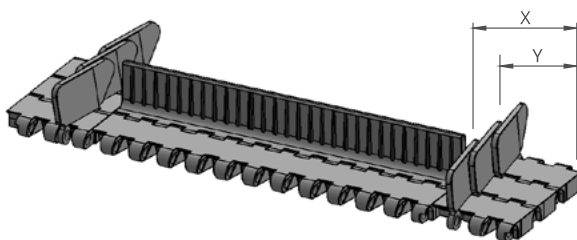

MD254 Series / Sidewall Technical Specifications

Possible Sidewall and Flight Indents	X		Y	
	mm	<i>inch</i>	mm	<i>inch</i>
Standard, no module cutting	33,5	1.32	14,9	0.59
Non-Standard	41,9	1.65	23,3	0.92
Standard, no module cutting	50,0	1.97	31,6	1.24
Non-Standard	58,6	2.31	39,9	1.57
Standard, module cutting necessary	66,9	2.63	48,5	1.91
Non-Standard	75,2	2.96	56,8	2.24

MD254 Series / Flight Technical Specifications

Possible Flight Indents for MD254 Series	Z	
	mm	<i>inch</i>
Standard, no module cutting	33,5	1.32
Standard, no module cutting	50,0	1.97
Standard, module cutting	83,5	3.29
Standard, no module cutting	100,0	3.94

*Non-standard flight indent is on request.

Note: Gap between flight and sidewall minimum 2-3 mm

MD254 Series *Engineering Information*

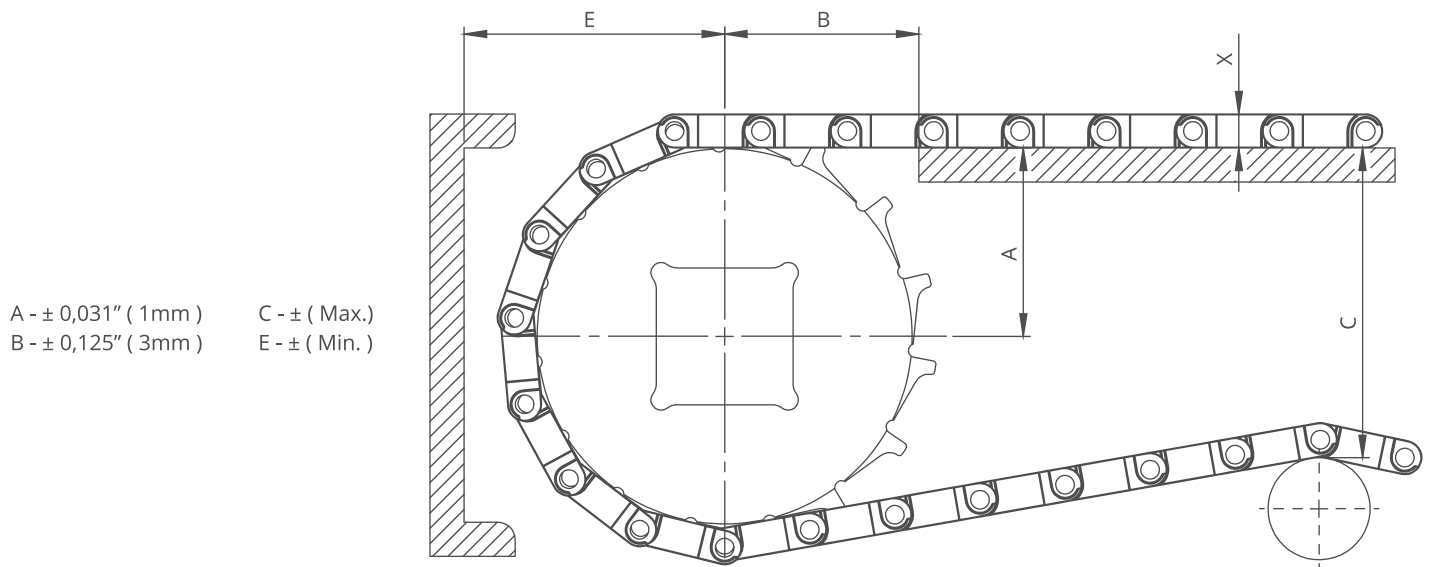

A - ± 0,031" (1mm) C - ± (Max.)
 B - ± 0,125" (3mm) E - ± (Min.)

MD254 Series / Conveyor Frame Dimensions

Sprockets Description			A		B		C		E		X	
Pitch Diameter		No.Teeth	Range (Bottom to Top)		inch	mm	inch	mm	inch	mm	inch	mm
inch	mm		inch	mm								
MD254 FG, MD254 C												
2.38	60,5	8	1.15	29,2	1.55	39,4	1.95	49,5	1.94	49,2	0.39	10,0
3.07	78,0	10	1.46	37,1	1.77	45,0	2.60	66,1	2.25	57,1	0.39	10,0
3.74	95,0	12	1.76	44,8	1.97	50,1	3.24	82,3	2.55	64,8	0.39	10,0
4.70	119,5	15	2.22	56,4	2.23	56,7	4.18	106,1	3.01	76,4	0.39	10,0
5.02	127,5	16	2.37	60,2	2.38	60,5	4.46	113,2	3.21	81,5	0.39	10,0
5.71	145,0	18	2.73	69,3	2.45	62,3	5.19	131,8	3.51	89,3	0.39	10,0
MD254 RR, MD254 GT												
2.38	60,5	8	1.15	29,2	1.55	39,4	1.95	49,5	2.18	55,4	0.64	16,3
3.07	78,0	10	1.46	37,1	1.77	45,0	2.60	66,1	2.48	63,1	0.64	16,3
3.74	95,0	12	1.76	44,8	1.97	50,1	3.24	82,3	2.79	70,9	0.64	16,3
4.70	119,5	15	2.22	56,4	2.23	56,7	4.18	106,1	3.25	82,7	0.64	16,3
5.02	127,5	16	2.37	60,2	2.38	60,5	4.46	113,2	3.46	87,8	0.64	16,3
5.71	145,0	18	2.73	69,3	2.45	62,3	5.19	131,8	3.76	95,5	0.64	16,3

MD254 Series / Slider Support System For Straight Running Belts

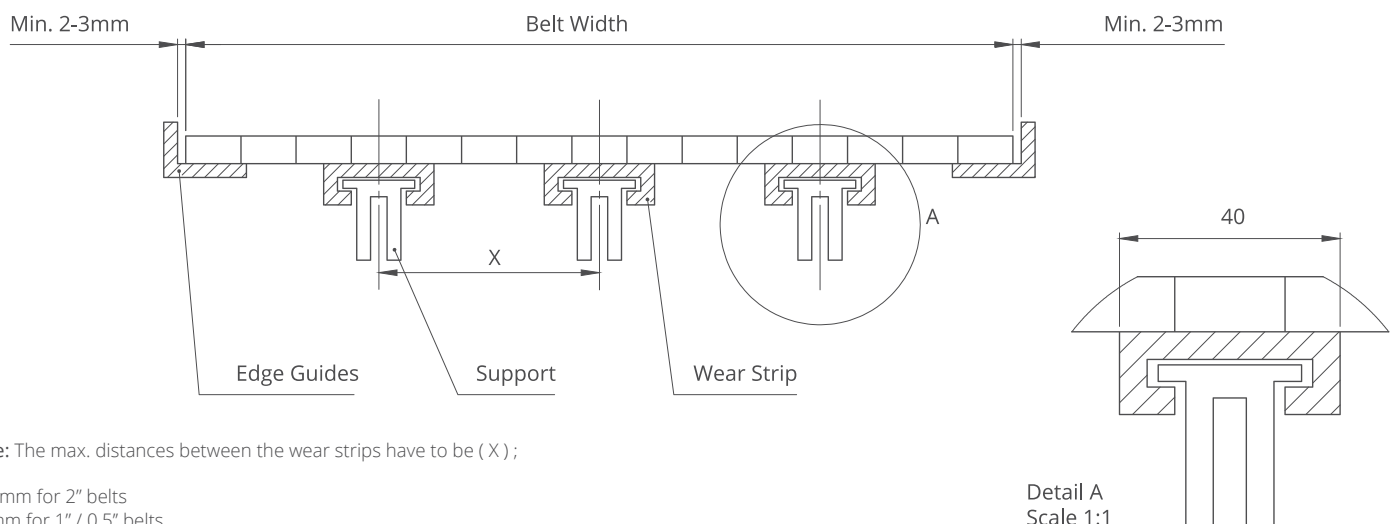

Note: The max. distances between the wear strips have to be (X) ;

125 mm for 2" belts
 80 mm for 1" / 0.5" belts

Detail A
 Scale 1:1

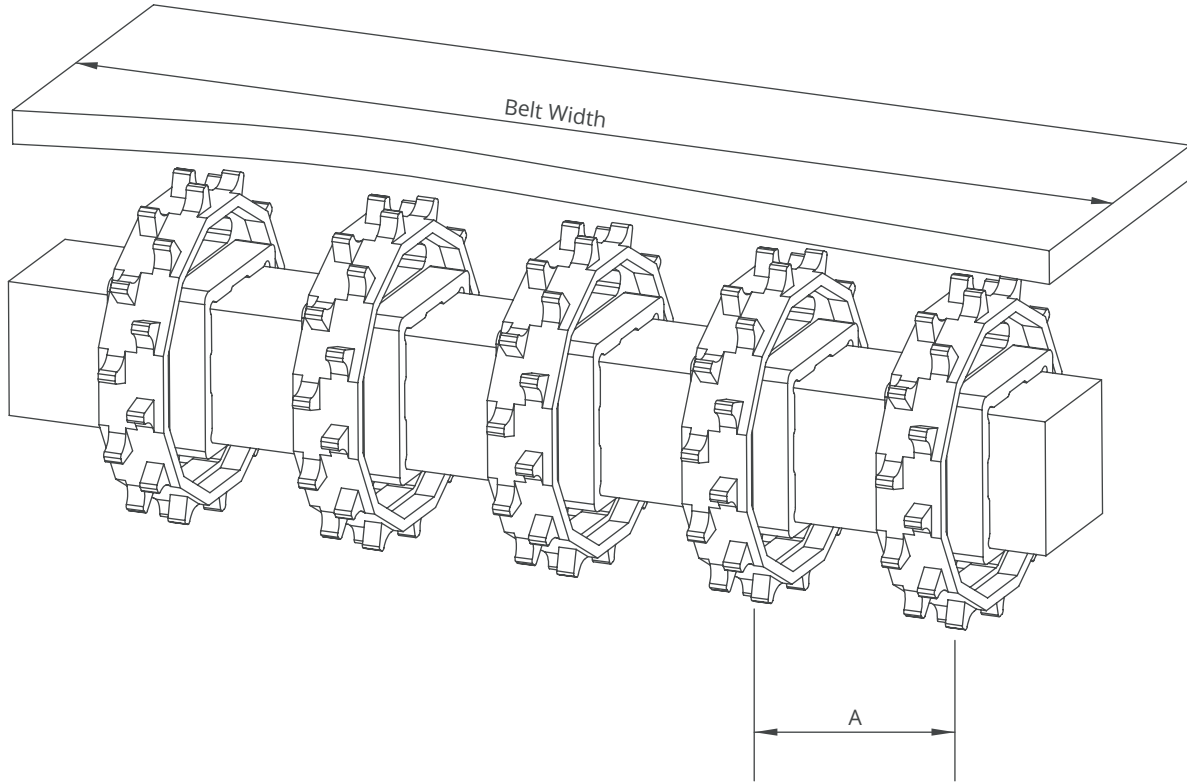

MD254 Series / Sprockets Arrangement

Standard Belt Width		Number of sprockets per shaft		A (mm/inch)	
mm	inch	Drive Shaft	Return Shaft	Min.	Max.
150,0	6.0	2	2	50/2	120/4.7
200,0	8.0	2	2	50/2	120/4.7
250,0	10.0	3	2	50/2	120/4.7
300,0	12.0	3	2	50/2	120/4.7
350,0	14.0	3	3	50/2	120/4.7
400,0	16.0	4	3	50/2	120/4.7
450,0	18.0	4	3	50/2	120/4.7
500,0	20.0	5	4	50/2	120/4.7
550,0	22.0	5	4	50/2	120/4.7
600,0	24.0	6	5	50/2	120/4.7
700,0	26.0	7	5	50/2	120/4.7
800,0	28.0	8	6	50/2	120/4.7
900,0	30.0	9	7	50/2	120/4.7
1000,0	32.0	10	7	50/2	120/4.7

Note: Number of sprockets depends on the belt load.